



Operation manual

Mobifreeze

M 270

Manufacturer:

LAUDA DR. R. WOBSEER GMBH & CO. KG

Schulze-Delitzsch-Straße 4+5

30938 Burgwedel

Germany

Telephone: +49 (0)9343 503-350

E-mail: info@lauda.de

Internet: <https://www.lauda.de>

Translation of the original operation manual

Q4DT-E_13-013_V6, 1, en_US 06/02/2026/LUS © LAUDA 2026

Table of contents

1	Safety.....	7
1.1	General safety instructions for the device.....	7
1.2	Obligations of the operator.....	8
1.3	EMC requirements.....	8
1.4	Software versions.....	8
1.5	Intended use.....	8
1.6	Unintended use.....	9
1.7	Foreseeable misuse.....	9
1.8	Type of power supply.....	10
1.9	Prohibition of modifications to the device.....	10
1.10	Ambient conditions and operating conditions.....	10
1.11	Materials.....	11
1.12	Time limits.....	11
1.13	Natural refrigerant.....	11
1.14	Application area.....	11
1.15	Description of personnel qualifications.....	12
1.16	Description of personal protective equipment.....	13
1.17	Safety fittings on the device.....	13
1.17.1	Alarm message.....	13
1.17.2	Sensor monitoring.....	13
1.17.3	Power failure / main battery failure.....	14
1.17.4	Data logger battery alarm.....	14
1.17.5	Overtemperature alarm.....	14
1.17.6	Low temperature alarm.....	14
1.18	Warning symbols on the device.....	14
1.19	Residual risks.....	15
1.20	Structure of warnings.....	15
2	Unpacking the device.....	17
2.1	Safety information.....	17
2.2	Unpacking.....	18
2.3	Operating manual ordering number.....	18
3	Transport.....	19
3.1	Regulations when transporting devices containing LiFePO4 batteries.....	19
3.2	Moving and transporting the ultra low temperature chest freezer.....	19
3.3	Option: Moving and transporting the ultra low temperature chest freezer fitted with a protective cover.....	21
3.4	Transport with an industrial truck.....	22
3.5	Option: Device version with recesses for forklift truck forks.....	23

4	Structure and function.....	25
4.1	Functional description of the Mobifreeze M 270.....	25
4.2	Structure of the Mobifreeze M 270 with and without the option for engagement recesses for forklift truck forks.....	26
4.3	Touch operating unit.....	30
4.4	Main battery monitor.....	33
4.4.1	Layout of main battery monitor.....	33
4.4.2	Calculating the charge level of the main battery.....	33
4.4.3	Synchronizing the battery monitor.....	34
4.5	Operating elements.....	34
4.5.1	Mains switch.....	34
4.5.2	Main battery switch.....	35
4.5.3	Push/pull handle.....	35
4.5.4	Dead man's brake with handle.....	35
4.5.5	Refrigeration compartment lock.....	36
4.6	Main battery.....	36
4.7	Rating label.....	37
4.8	Internal data logger.....	38
4.9	Limit values USr user level, factory setting.....	39
5	Before starting up.....	40
5.1	Installation.....	40
5.2	Selecting the menu language.....	42
5.3	Setting the date and time.....	43
5.4	Setting the temperature unit.....	44
5.5	Setting the value for the alarm suppression time after a power failure.....	45
5.6	Changing the record interval for the internal data logger.....	47
5.7	Changing the plant name.....	47
5.8	Displaying software information.....	48
5.9	Displaying copyright information.....	49
5.10	Wake up function.....	50
5.11	Installing modules.....	54
6	Commissioning.....	58
6.1	Establishing a mains connection.....	58
6.2	Switching the device on and off.....	59
6.3	Defining user profiles.....	61
6.4	Selecting a user profile.....	62
6.5	Changing the user profile password.....	63
6.6	Creating a new user name.....	64
6.7	Configuring user profile rights.....	65

6.7.1	Explanations of user rights.....	67
6.8	Activating auto logout.....	67
6.9	Selecting and displaying control curves.....	69
6.10	Setting alarm limit values.....	69
6.10.1	Setting the alarm delay limit value for the device lid.....	69
6.10.2	Setting a limit value for the low temperature alarm.....	71
6.10.3	Setting a limit value for the overtemperature alarm.....	73
7	Operation.....	75
7.1	Safety information.....	75
7.1.1	General safety instructions.....	75
7.1.2	Securing a device transported in a vehicle.....	76
7.1.3	Pushing/moving the device.....	77
7.1.4	Operating the device in fluctuating ambient temperatures.....	77
7.2	Adjustment of the cooling chamber temperature set point.....	77
7.3	Storing and retrieving refrigerated goods.....	78
7.4	Switching between mains and battery operation.....	79
7.5	Dead man's brake handle.....	80
7.6	Alarm management.....	80
7.7	Data transfer via USB.....	82
7.8	Acknowledging an alarm.....	83
7.9	Internal data logger and history function.....	84
7.10	Device operation with safety cooling.....	85
8	Maintenance.....	86
8.1	General safety instructions.....	86
8.2	Maintenance plan.....	87
8.3	Cleaning the device.....	87
8.4	Cleaning the condenser fins.....	88
8.5	Defrosting the refrigeration compartment.....	89
9	Faults.....	91
9.1	Calculation errors during synchronization of the battery monitor and manual synchronization.....	91
9.2	Alarms, warnings and errors.....	91
10	Decommissioning.....	95
10.1	General information on decommissioning.....	95
10.2	Main battery after decommissioning.....	95
11	Disposal.....	96
11.1	Disposing of refrigerant.....	96
11.2	Disposing of the main battery.....	96
11.3	Device disposal.....	96
11.4	Disposing of packaging.....	96

12	Technical data.....	97
12.1	Touch operating unit data.....	97
12.2	Main battery monitor data.....	97
12.3	Main battery and auxiliary battery data.....	97
12.4	Device data.....	98
12.5	Refrigerant and filling charge.....	99
13	General.....	100
13.1	Copyright.....	100
13.2	Technical changes.....	100
13.3	Warranty conditions.....	100
13.4	Contact LAUDA.....	100
13.5	Declaration of Conformity.....	101
13.6	Product Returns and Clearance Declaration.....	102
13.7	UN38.3 Test Report for LiFePO4 battery.....	103
14	Accessories.....	121
15	Index.....	126

1 Safety

1.1 General safety instructions for the device

IMPORTANT:

- Always read the operating manual carefully before operating the device.
- This operating manual is part of the device. If the device is passed on, the operating manual must be handed over with it.
- The information in this operating manual must therefore be kept at hand in the immediate vicinity of the device.
- Be sure to carefully store this copy of the operating manual.
- The operating manual is available on our website (<https://www.lauda.de>).
- The device must only be operated as intended under the conditions stated in this operating manual. Any other mode of operation is considered to be unintended use and could compromise the protection provided by the device.
- The device is not designed for use in medical applications in accordance with DIN EN 60601-1 and IEC 601-1.



If this operating manual is lost, contact LAUDA Service. You can find the contact information here ↪ Chapter 13.4 "Contact LAUDA" on page 100.

When operating the device, there is a risk of injury from low temperatures, fire and the presence of electrical energy. These risks posed by the device have been mitigated in the design to the extent possible in keeping with the applicable norms. The remaining risk can be reduced using one of the following measures:

- Safety equipment is available for the device. This equipment is crucial for device safety and must be controlled by the user. All maintenance intervals must be observed and appropriate maintenance activities must be performed to ensure the functionality of the equipment.
- The safety equipment for the device is described in this "Safety" chapter.
- Various warning symbols are located on the device. These symbols must be observed without fail.
The warning symbols on the device are described in this "Safety" chapter.
- Personnel and the protective equipment worn by personnel are also subject to specific requirements.
These requirements are described in this "Safety" chapter.
- The device may only be operated by trained personnel.
- Transport and move the device carefully. Never tilt the device. Slightly tilting the device is permitted, for example, during transport or when moving the device with an industrial truck.
- Never put the device into operation if:
 - it is damaged,
 - it is leaking (for example, refrigerant is escaping),
 - the mains cable and/or other cables are damaged.
- Switch off the device and pull out the mains plug, see ↪ Chapter 6.2 "Switching the device on and off" on page 59:
 - before starting service work, maintenance work or repair work
 - when moving the device fitted with a protective cover
 - when installing or removing modules or accessories



An overview of authorized personnel and protective equipment can be found in ↪ Chapter 1.15 “Description of personnel qualifications” on page 12 and ↪ Chapter 1.16 “Description of personal protective equipment” on page 13.



Refer to ↪ Chapter 1.20 “Structure of warnings” on page 15 for more information on the general structure of safety notices.

1.2 Obligations of the operator

The national regulations for operation applicable in the country in which the system is installed must be complied with.

In particular, the application of statutory regulations concerning operational safety must be observed.

The conditions for setting up the device must always be met. See also the information in the device specifications ↪ Chapter 12.4 “Device data” on page 98.

The device may only be used, maintained and repaired in accordance with the manufacturer’s instructions. It must not be modified or fitted with attachments without ensuring that the device is still safe. The safety of the device must be guaranteed at all times.

1.3 EMC requirements

Table 1: Classification in accordance with EMC requirements

Device	Immunity requirements	Emissions class	Customer power supply
Mobifreeze M 270	Table 1 (Industrial) in accordance with EN 61326-1	Emissions Class A in accordance with EN 55016-2	within the EU Domestic connection value ≥ 100 A

1.4 Software versions

This operating manual is valid for devices with the following software versions or higher.

Software	Valid from version
Single-board refrigeration controller	1.3.3
Operating unit	2.7.1138
Main battery monitor	1.09

1.5 Intended use

- The LAUDA Mobifreeze M 270 is a mobile ultra low temperature chest freezer, designed for industrial use.
- Temperatures between -50 °C and -86 °C can be set.

- The device is designed exclusively for the temperature control, storage and transport of non-hazardous substances, such as chemicals, pharmaceutical substances and medications.
- Only the integrated mains plug or the internal main battery may be used to operate the device.
- The ultra low temperature chest freezer is loaded and unloaded from above. The device lid must be opened and the goods inside secured to prevent them from sliding. Make sure that the contents are distributed evenly. Heavy loads should be placed at the lowest point possible in the interior, ideally on the floor of the compartment.
- The maximum permitted gradient or incline when moving the unloaded or loaded ultra low temperature chest freezer manually is 2%. The maximum payload is 100 kilograms.
- Suitable aids, such as a heavy-duty truck or industrial truck must be used to transport the mobile ultra low temperature chest freezer over longer distances or uneven ground. The chest freezer must be sufficiently secured in the process (securing of the load).

1.6 Unintended use

The following are considered examples of unintended use:

- Storage of highly flammable/self-igniting and/or explosive substances, acids and alkalis that are chemically unstable and/or release gases.
- Medical applications; the device does not have medical device approval and, as such, is not designed for use in medical applications in accordance with DIN EN 60601-1 and IEC 601-1.
- Installation and operation in hazardous areas and outside the permitted ambient conditions.
- Use for controlling the temperature of foodstuffs
- Use in aggressive or corrosive ambient conditions
- Storage of substances that attack the materials incorporated into the device, such as stainless steel, elastomers and sensors.
- Outdoor installation
- Storage of hazardous substances that emit harmful fumes
- Installation and operation in the vicinity of naked flames
- The presence or storage of animals or people in the refrigeration compartment

1.7 Foreseeable misuse

The following are considered cases of foreseeable misuse:

- Medical applications. The device does not have medical device approval and, as such, is not designed for use in medical applications in accordance with DIN EN 60601-1 and IEC 601-1.
- Transport of people/passengers
- Collision with other people and objects
- Moving/pulling the device with a motorized vehicle.
- Exceeding the maximum incline of 2% when moving the unloaded or loaded device manually.
- Exceeding the permissible payload, see the "Technical data" chapter.

1.8 Type of power supply

- Electrical energy
 - When connected to the mains power supply to operate the device
 - To charge the main battery

1.9 Prohibition of modifications to the device

Any technical modification of the device by the user is prohibited. Any damage resulting from unauthorized modification is not covered by customer service or the product warranty. Service work may only be performed by the LAUDA Service department or a service partner authorized by LAUDA.

Only original spare parts may be used.

The installation of modules, such as an external data logger or monitoring system, is only permitted/possible in compliance with the requirements in the "Installing modules" chapter. See ↗ Chapter 5.11 "Installing modules" on page 54 for more information.

1.10 Ambient conditions and operating conditions

When installing the device and planning the transport route, the following requirements must be observed:

- The installation site must be level and horizontal (maximum incline of 2%) and suitable for supporting the weight (empty weight and maximum payload) of the device.
- Activate the dead man's brake.
- Activate the locking casters.
- The transport route must not be slippery or icy.
- The device must be prevented from coming into contact with water (e.g. splash water or rain) along the transport route and at the installation site. Protection class IP 22 must be observed.
- Use up to a maximum height of 2,000 m above sea level
- Maximum relative humidity 80 percent, non-condensing
- Fluctuations of the mains voltage up to $\pm 10\%$ of the nominal voltage
- Overvoltage category II
- Pollution degree 2
- Positioned at a minimum distance of 150 mm away from walls or other devices so that the air drawn in for cooling can circulate freely.
- The condenser must not be covered or obstructed as air circulation must be guaranteed.
- In order to prevent an increase in the compartment temperature, resulting from a reduction in cooling capacity, the ambient temperature must not be exceeded, see technical data ↗ Chapter 12.4 "Device data" on page 98.
- In smaller installation rooms, ensure that the heat discharged from the device's active cooling system does not cause the ambient temperature (see technical data) to exceed the maximum limit.
- Ensure that the installation room has adequate ventilation and cooling.

The following requirements must **also** be observed when using the device in mobile applications:

- it is important to ensure that there is sufficient cooling (if necessary using air conditioning) in the transport vehicle. In order to prevent an increase in the compartment temperature resulting from a reduction in cooling capacity, the ambient temperature must remain within the limits specified in the technical data.
- The device must be secured properly during transportation. Ensure the load is secured properly and keep the ventilation grid on the device clear.
- Activate the dead man's brake.
- Activate the locking casters.
- The dead man's brake handle must not be secured in the pulled position.
- The device must not come into contact with the vehicle walls or other cargo items.
- The contents of the compartment must be adapted to the transport conditions and filled/secured accordingly.
- Minimize the time that the chest freezer spends in cold ambient conditions.
- The transport route must not be slippery or icy.
- The device must be prevented from coming into contact with water (e.g. splash water or rain) during transport. Protection class IP 22 must be observed.

1.11 Materials

All parts of the device are manufactured from high-quality materials adapted to withstand the operating temperature. The range of materials used includes high-quality stainless steels and high-quality, temperature-resistant plastics. The compartment is manufactured entirely from stainless steel.

1.12 Time limits

- The device is designed to operate continuously for 20,000 hours.
- Refer to the maintenance plan for information on maintenance intervals.

1.13 Natural refrigerant

The device operates using odorless, natural refrigerant. These refrigerants are flammable. There are no special installation requirements due to the low refrigerant charge and hermetically sealed design. The designation and refrigerant charge are specified on the type plate, see ↗ Further information on page 37 and also ↗ Chapter 5.1 "Installation" on page 40.

1.14 Application area

The device may only be used in the following areas.

- Logistics, production, quality assurance, research and development in an industrial environment
- Indoors
 - Exception: Properly secured in vehicle cargo holds
- Not installed outdoors
 - Exception: short routes in the open air in line with specified IP protection requirements

1.15 Description of personnel qualifications

Electrician

Electricians are able to perform work on electrical installations as well as identify and avoid potential dangers independently based on their professional training, knowledge and experience as well as knowledge of the relevant provisions.

Electricians are specially trained for the working environment in which they are active and know all the relevant standards and regulations.

Electricians must comply with the provisions of all applicable statutory accident prevention regulations.

Forklift driver

The forklift driver must be 18 years old or over and have physical, mental and character-related qualities that are suitable for driving industrial trucks that have a driver's seat or driver's cab.

Furthermore, the forklift driver has been trained to drive industrial trucks that have a driver's seat or driver's cab.

The forklift driver has demonstrated to the operator his or her ability to drive industrial trucks that have a driver's seat or driver's cab, and the operator then commissions the driver in writing to drive the vehicles.

Instructed person

The operator has informed the instructed person about the tasks assigned to them and the possible risks of improper behavior.

Refrigeration specialist

Refrigeration specialists are specially trained and certified for the specialist field in which they are active and know all the applicable standards and regulations. The certification includes the expertise required to avoid emissions, recover fluorinated greenhouse gases and safely handle refrigeration equipment of the relevant type and size.

Refrigeration specialists are able to carry out work on refrigeration systems and independently recognize and avoid possible dangers based on their professional training and experience.

A certificate relating to (EU) No. 2024/573 and (EU) No. 2015/2067 must be available.

Specialized personnel

Specialized personnel are able to perform the work assigned to them as well as identify and avoid potential dangers independently based on their professional training, knowledge and experience as well as knowledge of the relevant provisions.

1.16 Description of personal protective equipment



Cold protection gloves

Cold protection gloves are leather safety gloves that are resistant to acid and cold.

Safety gloves are used to protect the hands when touching refrigerated components and small quantities of refrigerants.



Protective gloves

Protective gloves are worn to prevent injuries when removing external protective panels.



Safety glasses

Safety glasses are used to protect the eyes from flying parts and liquid splashes.



Safety shoes

Safety shoes are worn to provide protection against heavy falling objects and prevent slipping on slippery surfaces. They also protect the feet when removing exterior protective panels.

1.17 Safety fittings on the device

1.17.1 Alarm message

In the event of a malfunction, an alarm is triggered.

Each alarm is indicated acoustically in the form of an alarm signal (1 second on – 1 second off) and visually on the Touch operating unit display.

All alarms that occur are saved in the internal data logger.

1.17.2 Sensor monitoring

The controller's temperature probe is continuously checked for short circuits and interruptions.

In the event of a malfunction, an alarm message is activated, see [Chapter 1.17.1 "Alarm message"](#) on page 13.

If the sensor develops a fault, the emergency program starts. The device cools alternately for 30 minutes with the compressor running, and then stops for 10 minutes.

Note:

- During the emergency program, the temperature may vary from the set temperature in the compartment.

1.17.3 Power failure / main battery failure

If a power failure occurs or the device is disconnected from the mains power, it switches to battery mode. This transition usually occurs without interruption.

If the user switches off the main battery or the battery is completely discharged, meaning that battery operation is no longer possible, an acoustic warning signal sounds after approximately 5 seconds (1 second on – 1 second off). The [power failure] fault message remains on the Touch operating unit display until it is acknowledged.

In the event of a complete power failure, the battery of the internal data logger will keep the Touch operating unit display and data recording (internal data logger) operational for approximately 35 hours.

1.17.4 Data logger battery alarm

If the battery in the internal data logger develops a fault, a corresponding message and the current temperature appear alternately in text form on the display.

An acoustic alarm also sounds (1 second on – 1 second off).

Always observe the legal regulations when disposing of a faulty battery from the internal data logger.

1.17.5 Overtemperature alarm

The overtemperature protection is a warning device that is activated when the temperature in the refrigeration compartment exceeds the specified upper limit.

This information is shown on the Touch operating unit display.

An acoustic alarm also sounds (1 second on – 1 second off).

1.17.6 Low temperature alarm

The low temperature protection is a warning device that is activated when the temperature in the refrigeration compartment falls below the specified lower limit.

This information is shown on the Touch operating unit display.

An acoustic alarm also sounds (1 second on – 1 second off).

1.18 Warning symbols on the device

Cold surfaces



"Cold surface" warning symbols are affixed to the device. This symbol warns of cold surfaces on the device. These surfaces must not be touched during operation. Personal protective equipment must be worn before coming into contact with these surfaces during other operation phases such as servicing.

Flammable



- The “Flammable” warning symbol is attached to devices filled with natural refrigerants.

This symbol warns of the flammability of natural refrigerant.

LiFePO4 battery



- The device is fitted with a LiFePO4 battery.

1.19 Residual risks

The safety instructions/warning information in the operating instructions describe any residual risks on the device.

1.20 Structure of warnings

Dangerous

- A warning of "dangerous" indicates an **immediately dangerous** situation.
- If this warning is not observed, then **death** or **severe, irreversible injury** could occur.

 DANGER! Type and source
Consequences of not following instructions
<ul style="list-style-type: none"> ● Measure 1 ● Measure...

Warning

- A warning of "warning" indicates a **possibly dangerous** situation.
- If this warning is not observed, then **death** or **severe, irreversible injury** could occur.

 WARNING! Type and source
Consequences of not following instructions
<ul style="list-style-type: none"> ● Measure 1 ● Measure...

Caution

- A warning of "caution" indicates a **possibly dangerous** situation.
- If this warning is not observed, then **minor, reversible injury** could occur.

 CAUTION! Type and source	
	Consequences of not following instructions
	<ul style="list-style-type: none">● Measure 1● Measure...

Notice

A "notice" warns that dangers to property or the environment may exist.

 NOTICE! Type and source	
	Consequences of not following instructions
	<ul style="list-style-type: none">● Measure 1● Measure...

2 Unpacking the device

2.1 Safety information



WARNING!
Leaks in the cooling circuit due to transport damage

Fire

If you discover that the transport packaging is damaged:

- Place/store the device in a well-ventilated location with no sources of ignition.
- Do not operate the device.
- Contact LAUDA Service.



WARNING!
LiFePO4 battery damaged during transport

Fire, breakages, heat, leaks

- Protect the battery system from damage.
- Immediately disconnect a faulty device from the mains power.
- Switch off the battery system.
- If necessary, use a suitable extinguishing agent to extinguish a LiFePO4 battery fire.
- Contact LAUDA Service.



CAUTION!
Transport damage

Cutting

- Closely inspect the device for transport damage prior to starting up.
- Never operate a device that has sustained transport damage.



NOTICE!
Aids/lifting equipment used during unpacking

Impact, crushing, material damage

- Use suitable aids when unpacking.
- Use suitable lifting equipment.
- Have the device unpacked professionally by specialized personnel.

2.2 Unpacking

- Personnel: ■ Specialized personnel
- Protective equipment: ■ Safety shoes
 ■ Protective gloves

1. Place the device on a level surface.
2. Unpack the device.



Keep the original packaging of your device for subsequent transportation.

3. Check the device and accessories for completeness and transport damage immediately after delivery.



If the transport packaging, device or accessories are damaged contrary to expectations, immediately inform the shipping company so that a damage report can be compiled and the transport damage inspected. Also notify the LAUDA Service department immediately. Refer to ↗ Chapter 13.4 “Contact LAUDA” on page 100 for contact details, and place/store the device in a well-ventilated location with no sources of ignition.

Note on fire extinguishers suitable for extinguishing a LiFePO₄ battery fire:



If the LiFePO₄ battery catches fire, use suitable fire extinguishers to extinguish the fire. These fire extinguishers should be designed specifically to extinguish battery fires. They may contain classic extinguishing agents such as CO₂ powder or normal foam, or may be gel fire extinguishers or special lithium-X extinguishers.

2.3 Operating manual ordering number

Device type	Designation	Language	Quantity	Ordering number
Mobifreeze M 270	Operating manual	German	1	Q4DT-E.13-013-DE
		English	1	Q4DT-E.13-013-EN
		French	1	Q4DT-E.13-013-FR
Mobifreeze M 270	Warranty card		1	----

3 Transport

3.1 Regulations when transporting devices containing LiFePO4 batteries

When transporting ultra low temperature chest freezers containing LiFePO4 batteries on a transport vehicle (truck or similar), observe the following regulations.

- The device/package must be marked with a danger label (or a corresponding sticker, size 10x10 cm) indicating "Hazard Class 9" and the identification number "UN3481".
- The test certificate of the LiFePO4 battery must be present. This certificate must be sent to the shipping company beforehand. The certificate can be found in the "General" chapter of this operating manual, see ↗ Chapter 13.7 "UN38.3 Test Report for LiFePO4 battery" on page 103, and downloaded in PDF format from www.lauda.de in the "Service" area: <https://www.lauda.de/en/services/download-center/filter/default/mobifreeze>.
- A "document for the transportation of hazardous goods by road" including number UN3481 and the gross weight of the device (net weight of the ultra low temperature chest freezer and corresponding payload) must be prepared and transported together with the ultra low temperature chest freezer.

3.2 Moving and transporting the ultra low temperature chest freezer



WARNING!

Operating error when pushing, rollover hazard due to casters

Risk of injury from rolling over, impacts

- Do not roll the device over your feet or other parts of your body.
- Move the device carefully, ask several people to help, if necessary.
- Wear safety shoes.
- Avoid collisions with other people and objects.
- Avoid foreseeable misuse, see ↗ Chapter 1.7 "Foreseeable misuse" on page 9.

Personnel: ■ Instructed person

Protective equipment: ■ Protective gloves

■ Safety shoes

Note the following when pushing/moving or transporting the device in a truck:

1. Disconnect the device from the mains power.
 - ▶ If the battery switch has also been switched off, an alarm will sound after a preset time, see "Setting the value for the alarm suppression time after a power failure". This value must be set according to: ↗ Chapter 5.5 "Setting the value for the alarm suppression time after a power failure" on page 45
2. Wind up the mains cable.

3. Release the locking casters.
4. Pull and hold the dead man's brake handle, then push and maneuver the device using the push handle.



Due to the net weight of the device and the payload, it makes sense to have several people push/move the ultra low temperature chest freezer.

Note the following when parking the device:

1. Release the dead man's brake handle on the push handle.
2. Secure the locking casters.
 - ▶ Device can be connected to the mains power supply, for further information, see ↪ Chapter 6.1 “Establishing a mains connection” on page 58.

Note the following when parking the device inside a vehicle (industrial truck):



WARNING!
Uncontrolled device movement during transport

Danger of injury, device damage

- Secure the load properly to prevent it from moving or sliding.
- Activate the locking casters.
- Activate the dead man's brake. The dead man's brake handle must not be secured in the pulled position.
- The load must not come into contact with the outer walls of the vehicle or any other cargo items.

1. Activate the dead man's brake.
2. Activate the locking casters.
3. Ensure the load is secured properly to prevent it from moving or sliding.
4. Make sure that the load cannot come into contact with the outer walls of the vehicle or other cargo items.



CAUTION!
Transport damage

Cutting

- Closely inspect the device for transport damage prior to starting up.
- Never operate a device that has sustained transport damage.

 NOTICE! Setting up the device	Equipment damage/material damage/malfunction
	<ul style="list-style-type: none"> The device must be at the permissible ambient temperature when started up. If not, the device must be acclimatized.

3.3 Option: Moving and transporting the ultra low temperature chest freezer fitted with a protective cover

 WARNING! Operating error when pushing, rollover hazard due to casters	Risk of injury from rolling over, impacts
	<ul style="list-style-type: none"> Do not roll the device over your feet or other parts of your body. Move the device carefully, ask several people to help, if necessary. Wear safety shoes. Avoid collisions with other people and objects. Avoid foreseeable misuse, see Chapter 1.7 “Foreseeable misuse” on page 9.

- Personnel: Instructed person
- Protective equipment: Protective gloves
 Safety shoes

Note the following when pushing/moving the device fitted with a protective cover and transporting it in a heavy-duty truck:

1. Switch on the battery switch.
2. Disconnect the device from the mains power.
3. Wind up the mains cable.
4. Mounting/attaching spacers for the protective cover.
5. Fit the protective cover on the device.
6. Release the locking casters.
7. Pull and hold the dead man's brake handle, then push and maneuver the device using the push handle.





Due to the net weight of the device and the payload, it makes sense to have several people push/move the ultra low temperature chest freezer.

Note the following when parking the device fitted with a protective cover:

1. Release the dead man's brake handle on the push handle.
2. Secure the locking casters.

3. Remove the protective cover.
4. Remove/unhook the spacers for the protective cover.
 - ▶ Switch on the battery switch if necessary.
 - ▶ Device can be connected to the mains power supply, for further information, see [Chapter 6.1 “Establishing a mains connection”](#) on page 58.

 CAUTION! Transport damage	
Cutting	<ul style="list-style-type: none"> ● Closely inspect the device for transport damage prior to starting up. ● Never operate a device that has sustained transport damage.
 NOTICE! Setting up the device	
Equipment damage/material damage/malfunction	<ul style="list-style-type: none"> ● The device must be at the permissible ambient temperature when started up. If not, the device must be acclimatized.

3.4 Transport with an industrial truck

The ultra low temperature chest freezer can be transported on an industrial truck under the following conditions:

- The device must be secured to the industrial truck (secure load).

Personnel: ■ Forklift driver

Protective equipment: ■ Safety shoes
 ■ Protective gloves

1. Only insert the forks of the industrial truck into the wider side of the device.
2. Insert the forks so far that they protrude out of the opposite side.
3. Make sure that the device cannot tip over if the center of gravity is off-center (secured load).
4. Lift the device as gently as possible and start transportation. When driving over bumps and braking, ensure that the package cannot tip or slide.
5. Always check the device for transport damage after each transport operation.



DANGER!
Transport damage

Electric shock, fire

- Closely inspect the device for transport damage prior to starting up.
- Never operate a device that has sustained transport damage.
- Always place/store a device with transport damage in a well-ventilated location with no sources of ignition.

3.5 Option: Device version with recesses for forklift truck forks

The ultra low temperature chest freezer with engagement recesses for forklift truck forks can be transported with an industrial truck under the following conditions:

- The device must be secured to the industrial truck (secure load).

Personnel: ■ Forklift driver

Protective equipment: ■ Safety shoes

■ Protective gloves

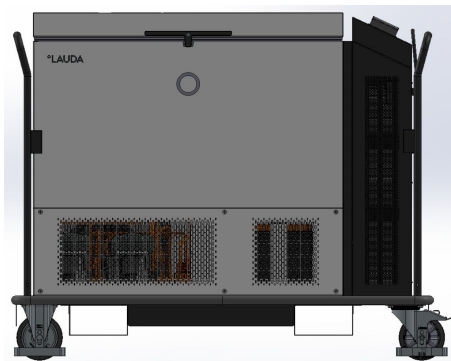

Fig. 1: Transporting with an industrial truck with engagement recesses for forklift truck forks

1. Only insert the forks of the industrial truck into the wider side of the device.
2. Insert the forks so far that they protrude out of the opposite side.



When inserting and laterally adjusting forklift truck forks, do not damage the engagement recesses on the device.

3. Make sure that the device cannot tip over if the center of gravity is off-center (secured load).
4. Lift the device as gently as possible and start transportation. When driving over bumps and braking, ensure that the package cannot tip or slide.
5. Always check the device for transport damage after each transport operation.



DANGER!
Transport damage

Electric shock, fire

- Closely inspect the device for transport damage prior to starting up.
- Never operate a device that has sustained transport damage.
- Always place/store a device with transport damage in a well-ventilated location with no sources of ignition.

4 Structure and function

4.1 Functional description of the Mobifreeze M 270

The LAUDA ultra low temperature chest freezer Mobifreeze M 270 is a mobile, actively temperature-controlled ultra low temperature chest freezer that operates independently of the mains power supply and has been designed for the internal or external transport of sensitive active ingredients or samples requiring storage at a constant, monitored temperature.

The integration of a powerful battery and optimized insulation ensures compliance with cold chain requirements in intralogistics and for "factory transport" in road logistics. With all-round impact protection, sturdy push handles, a braking system and heavy-duty casters, the ultra low temperature chest freezer is optimized for harsh logistics requirements. The ultra low temperature chest freezer can be freely adjusted to any temperature between -50°C and -86°C, and offers the same controlled storage conditions (e.g. temperature stability) as stationary ultra low temperature chest freezers.

The device operates with two high-performance compressors. The air-cooled condenser on the back of the device releases the extracted heat from the refrigeration compartment into the ambient air. The temperature controller keeps the preset temperature constant and has an internal data logger. The current temperature in the cooling chamber is shown on the controller display.

A separate display shows the charge level of the integral high-performance battery (main battery), which ensures mains-independent operation for a minimum of 4 hours ⁽¹⁾. Flexible changeovers between mains operation and battery operation ensure a high level of product and transport safety.

Natural refrigerants are used to ensure environmentally-friendly, future-proof operation.

The device is optimized for operation at the respective maximum set temperature and also achieves maximum temperature stability (over time) at this temperature.

⁽¹⁾ = see table overview below

Working temperature	Ambient temperature	Battery life
		100% --> 20%
- 80°C	16°C–28°C	4.0 hours
- 80°C	37°C	2.5 hours
- 80°C	5°C	4,0 hours
- 80°C, with device fitted with a protective cover	37°C	1.0 hours
- 50°C	37°C	4.5 hours
- 50°C	5°C	7.0 hours

4.2 Structure of the Mobifreeze M 270 with and without the option for engagement recesses for forklift truck forks

Front view of device

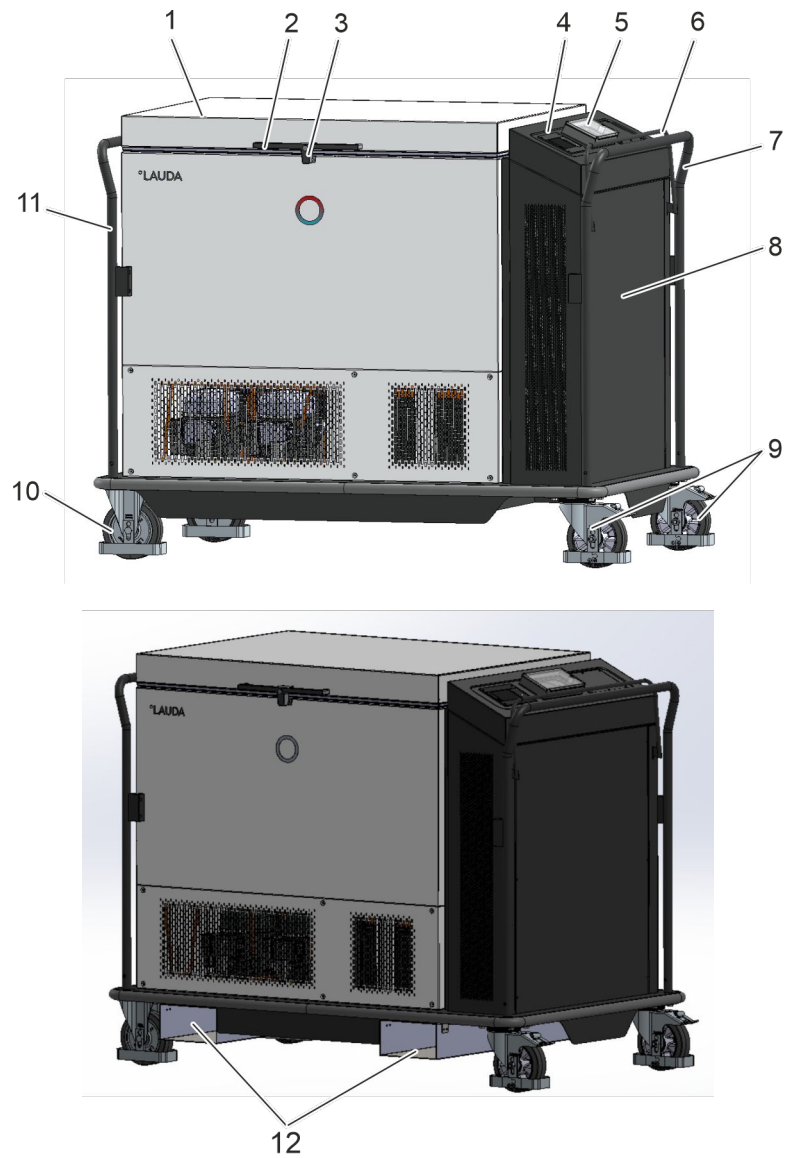

Fig. 2: Front view

1	Device lid, refrigeration compartment
2	Refrigeration compartment lid handle
3	Refrigeration compartment lock (key)
4	Operating console
5	Cover (depending on device version)
6	Dead man's brake handle
7	Push handle
8	Device front cover/panel
9	Locking casters

10	Castors
11	Pull handle on the back of the device
12	Option: Stainless steel engagement recesses for forklift truck forks

Rear view of device

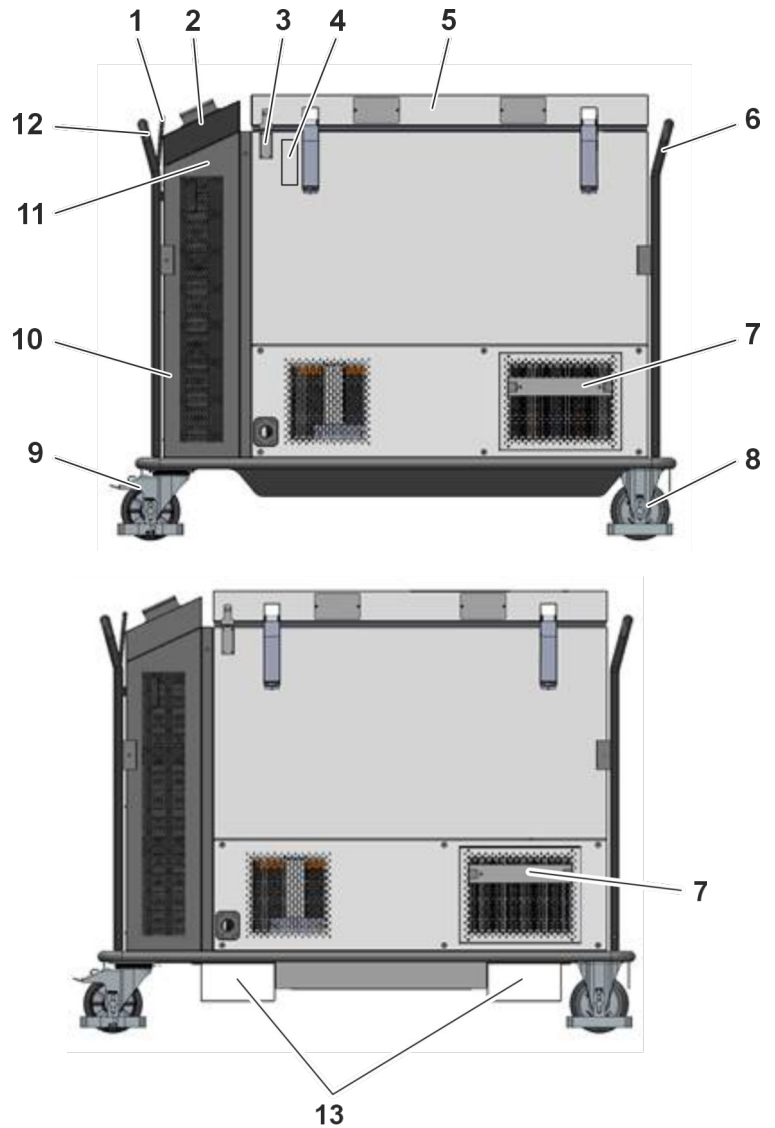

Fig. 3: Rear view

1	Dead man's brake handle
2	Operating console on the front of the device
3	Device lid contact switch
4	Type plate
5	Device lid, refrigeration compartment
6	Pull handle on the back of the device

7	Spacer for protective covers
8	Castors
9	Locking casters
10	Mains plug with cable rolled up inside the freezer
11	Front of device
12	Push handle on the front of the device
13	Option: Stainless steel engagement recesses for forklift truck forks

Operating console

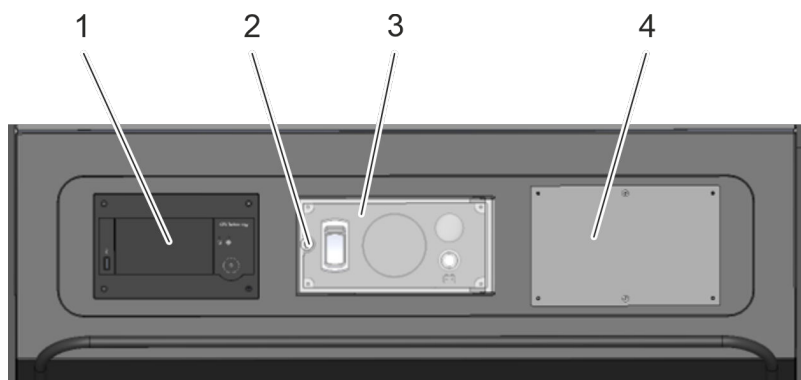

Fig. 4: Operating console with closed cover

1	Touch operating unit
2	Cover lock (key)
3	Cover closed
4	Blank cover (customer has option of installing a monitoring system)

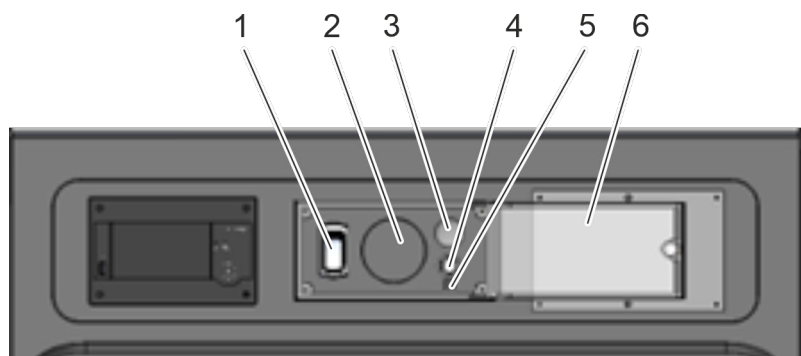

Fig. 5: Operating console with open cover

1	Mains switch
2	Main battery monitor

3	Duct sealed with plug (can be used for customer's connections)
4	Main battery switch
5	Battery symbol
6	Cover open

The cover must be unlocked and opened before the mains switch, main battery monitor or main battery switch can be operated and the duct used.

Loading height limit in the refrigeration compartment

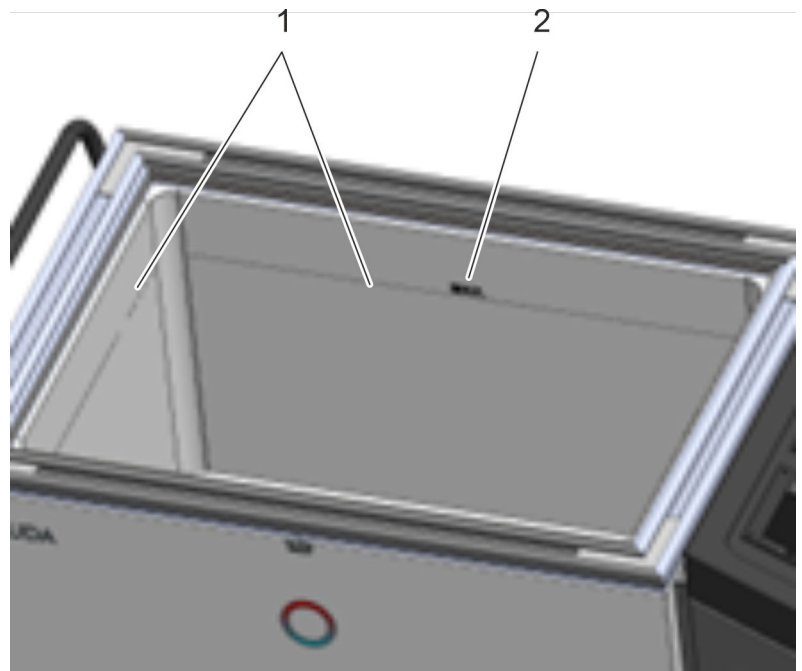

Fig. 6: Refrigeration compartment with limit line

1	Loading height limit line in the refrigeration compartment (all the way round)
2	"MAX" marking for maximum loading height in the refrigeration compartment

The maximum loading height in the refrigeration compartment of the ultra low temperature chest freezer must not be exceeded in order to ensure compliance with the temperature uniformity specification.

4.3 Touch operating unit

General overview of Touch operating unit



Fig. 7: Touch operating unit

1	Touch operating unit display
2	Status indicator LED
3	USB interface

Touch operating unit display

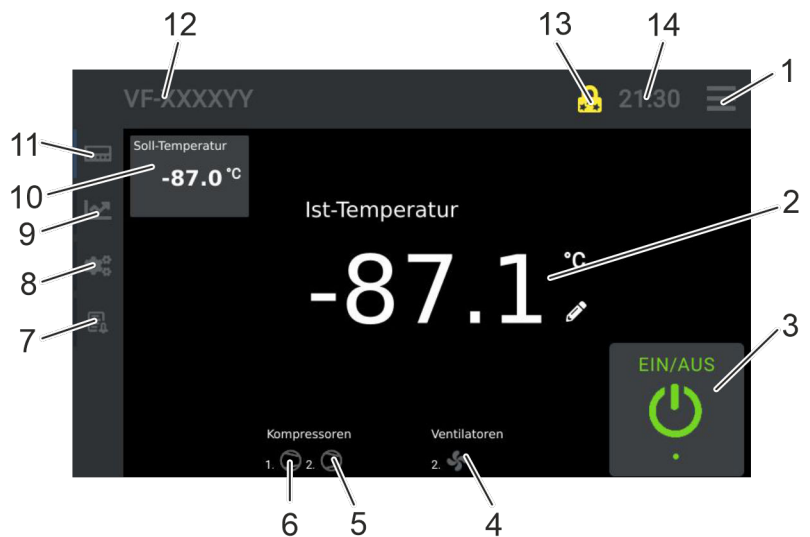

Fig. 8: Touch operating unit

1	Menu
2	Current cooling chamber temperature display
3	ON/OFF status indicator
4	Fans, rotating symbol = fan on condenser is active
5	Compressor 2, two-stage, rotating symbol = compressor is active

6	Compressor 1, single-stage, rotating symbol = compressor is active
7	History of the commander or a connected controller
8	Controller parameters
9	Internal data logger, history
10	Set point cold room temperature
11	Controller overview
12	Type
13	Login and user profile display
14	Time



Pressing the button (11) displays the controller overview.

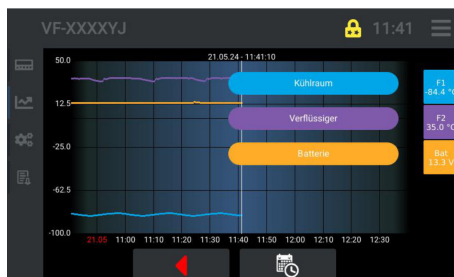

Pressing the button (9) displays the internal data logger and the history view.

A- Alarme	54
b- Tasten und Schalteingänge	7
C- Kreis 1	10
F- Lüfter Kreis 1	59

Pressing the button (8) allows the user to view and edit the controller parameters.

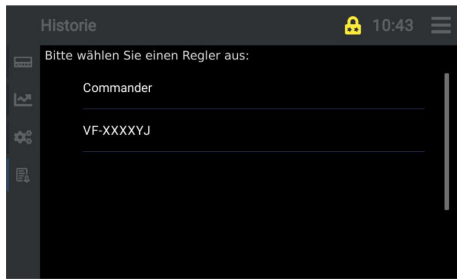

Pressing the button (7) opens the history of the commander or of a connected controller.

Status indicator LED

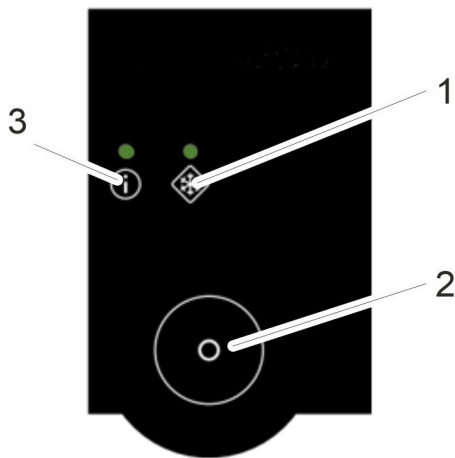

1	LED 2, no function
2	Toggle button
3	LED 1, normal cooling (i symbol)

Fig. 9: Status indicator LED

LED 1 (normal cooling)



Fig. 10: LED 1

LED status	Description
Green	Active, no errors/faults during normal cooling
Red	All other instances, such as: <ul style="list-style-type: none"> - Connection failure - Collective fault - Standby

4.4 Main battery monitor

4.4.1 Layout of main battery monitor

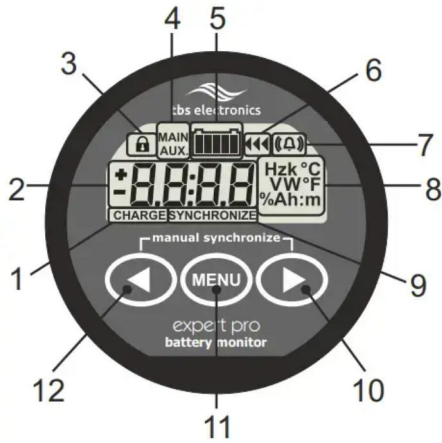

Fig. 11: Main battery monitor

1	"Battery charging" indicator	The "Charge" warning flashes when the main battery charge falls below 30%.
2	Numerical value display field	The display field displays the numerical values for the battery monitor's electrical information and parameters.
3	"Setup lock" display	By activating the lock, the functional parameters can still be viewed but not modified.
4	"Main" battery indicator	Only the main battery is connected to the main battery monitor. The display always shows "Main".
5	Charge level progress bar	Charge level of the main battery is visually displayed.
6	"Charging progress" indicator	The arrows represent the charge flow.
7	"Alarm activated" indicator	The alarm is displayed if the main battery charge falls below 20%.
8	Units	Shows the units of the relevant measuring values.
9	"Synchronization" indicator	This means that a complete charging cycle of the main battery must be performed.
10	Next value or right button	Go to the "next" display.
11	Menu button for service only	Settings may only be performed in the menu of the main battery monitor by a LAUDA service technician or authorized person.
12	Previous value or left button	Go back to the "previous" display.

4.4.2 Calculating the charge level of the main battery

The current charge level of the main battery, which is displayed on the battery monitor, is determined by the electrical charge, whereby the current flow from the main battery is measured over time by a measuring resistor.

The calculated electrical charge is subtracted from the nominal capacity of the main battery during discharging.

4.4.3 Synchronizing the battery monitor

For the battery monitor to synchronize automatically and display "Full" after charging, **three parameters** must be met:

- The battery voltage must be greater than **27 volts** for **120 seconds** and the charging current less than **3 amperes**.

Please note:



The battery monitor synchronizes with each full charge, which means that long periods of inactivity without using the device in battery mode can negatively affect the accuracy of the charge level.

The same applies if the main battery is not fully charged for an extended period of time, which can lead to discrepancies between the displayed charge level and the actual charge level. These discrepancies are not critical and can be corrected by fully charging the battery. Once a full charge has been confirmed, the battery monitor can be synchronized manually.

See  Chapter 9.1 "Calculation errors during synchronization of the battery monitor and manual synchronization" on page 91 for more information.

4.5 Operating elements

4.5.1 Mains switch



Fig. 12: Mains switch

The mains switch can be set to the following positions:

- Position [I] switches on the device under mains power. Mains voltage is supplied to the device and the main battery is charged provided that the mains cable is connected to the mains power supply.
- Position [O] switches off the device from the mains power. If the main battery switch is set to the [I] position, the device receives power from the main battery and can continue to operate. In this position, the main battery switch lights up green.



If the mains switch is set to the [O] position, the device does not receive power from the mains power supply and the main battery is not charged.

However, the device can still operate if the battery switch is set to the [I] position and it receives power from the main battery.

4.5.2 Main battery switch



Fig. 13: Main battery switch off

The main battery switch is not pressed:

- In the [O] position, the main battery is switched off and the device does not receive power from the main battery. If the device is not supplied from the mains power, it is not operational.
- In this state, the main battery switch does not light up.

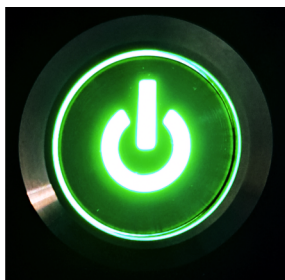

Fig. 14: Main battery switch on

The main battery switch has been pressed:

- In the [I] position, the main battery is connected. The device receives power from the main battery if no power is received from the mains supply.
- In this state, the main battery switch lights up.

4.5.3 Push/pull handle

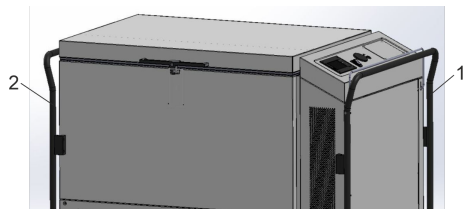

Fig. 15: Handles

- 1 Push handle on the operating console/front of the device
- 2 Pull handle on the back of the device

4.5.4 Dead man's brake with handle

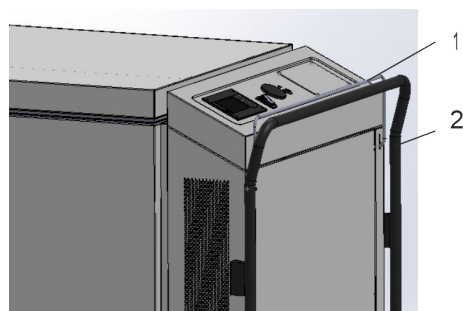

Fig. 16: Dead man's brake

- 1 Dead man's brake handle
- 2 Push handle

When the device is moved using the push handle, the brake handle must be pulled at the same time. This releases the dead man's brake and allows the device to be moved. Letting go of the brake handle activates the dead man's brake and prevents the device from moving.

Note the following information, see ↗ Chapter 1.5 “Intended use” on page 8, ↗ Chapter 1.7 “Foreseeable misuse” on page 9 and ↗ Chapter 1.10 “Ambient conditions and operating conditions” on page 10.

4.5.5 Refrigeration compartment lock

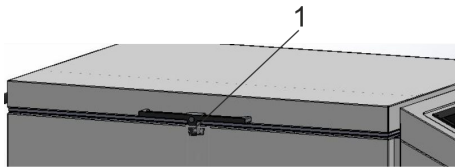

Fig. 17: Refrigeration compartment lock

1 Refrigeration compartment lock

The refrigeration compartment can be locked with the key provided.

Never keep the keys near the device or within the reach of children or unauthorized persons.

4.6 Main battery

The Mobifreeze M 270 is fitted with a rechargeable, high-performance lithium-iron phosphate battery. This main battery is designed to ensure mobile operation of the Mobifreeze M 270 for a minimum period of 4 hours (1) while disconnected from the mains power supply.

(1) = see table overview below

Working temperature	Ambient temperature	Battery life
		100% --> 20%
100% --> 20%	16°C–28°C	4.0 hours
- 80°C	37°C	2.5 hours
- 80°C	5°C	4,0 hours
- 80°C, with device fitted with a protective cover	37°C	1.0 hours
- 50°C	37°C	4.5 hours
- 50°C	5°C	7.0 hours

To use the device in mobile battery mode, disconnect the mains plug from the power socket and allow the cable to wind itself up. If the battery power supply is not yet active, press the main battery switch to switch on the supply. After a brief pause, the device will switch to battery mode. The main battery switch lights up.

The main battery monitor displays the charge level as a percentage and the expected remaining operating time until the battery is fully discharged. Please note that this value only represents the actual situation after the device has been operating on battery power for some time.

If the main battery charge level falls below 30%, [CHARGE] will appear on the display of the main battery monitor.

If the main battery charge level falls below 20%, the main battery switch no longer lights up and an alarm bell will appear on the main battery monitor. The cooling unit switches off. The [mains power failure] alarm is reported to the Touch operating unit, and an alarm sounds. To continue operation and recharge the main battery, connect the mains plug on the device to a power socket.

Please note:

The mains cable must be pulled out from the device and completely unrolled before connecting the mains plug to the power supply.

Then acknowledge the [battery mode/power failure] alarm on the Touch operating unit.

Once the device has been connected to the power and the mains switch is set to "On" [1], the main battery will start charging regardless of the (On/Off) position of the battery switch.

Once the charge level of the main battery exceeds 30% again, the alarm symbol on the battery monitor will disappear and the main battery switch will light up again. If the main battery is fully charged, [FULL] will appear on the main battery monitor. The display then changes to 100 percent.

If the device is not in use, note the following:

If the device is not in use and is disconnected from the power supply, the main battery supply must be switched off at the battery switch. Otherwise, standby mode will drain the main battery within approximately 24 hours.

4.7 Rating label

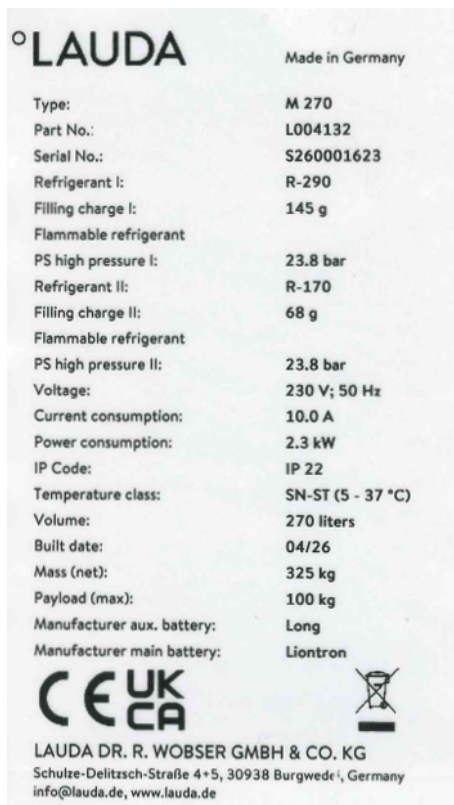

Fig. 18: Example of type plate

Specification	Example	Description
°LAUDA	Made in Germany	Manufacturer LAUDA, made in Germany
Type:	M 270	Device type
Part No.:	L00xxxx	Device item number
Serial no.:	S26xxxxxxx	Device serial number

Specification	Example	Description
Refrigerant I:	R 290	Refrigerant used in refrigerant circuit 1 of the appliance for cooling.
Filling charge I:	145 g	Filling weight of refrigerant 1 in g
Flammable refrigerant		Flammable refrigerant, "Risk of fire or explosion" warning symbol, see beneath the type plate
PS high pressure I:	23.8 bar	Maximum safety pressure in refrigerant circuit 1 in bar
Refrigerant II:	R 170	Refrigerant used in refrigerant circuit 2 of the appliance for cooling.
Filling charge II:	68 g	Filling weight of refrigerant 2 in g
Flammable refrigerant		Flammable refrigerant, "Risk of fire or explosion" warning symbol, see beneath the type plate
PS high pressure II:	23.8 bar	Maximum safety pressure in refrigerant circuit 2 in bar
Voltage:	230 V; 50 Hz	Mains voltage in V/ frequency in Hz
Current consumption:	10.0 A	Current consumption in A
Power consumption:	2.3 kW	Power consumption in kW
IP code:	IP 22	Protection level / protection class
Temperature class	SN-ST (5–37°C)	Temperature class
Volume:	270 liters	Volume of refrigeration compartment in liters
Built date:	04/26	Date of manufacture, month/year
Weight (net):	325 kg	Net weight in kg
Payload (max)	100 kg	Maximum payload in kg
Manufacturer aux. (auxiliary) battery	Long	Manufacturer of the auxiliary battery
Manufacturer main battery	Liontron	Manufacturer of the main battery

4.8 Internal data logger

The internal data logger starts automatically and records

- the refrigeration compartment temperature
 - the condenser temperature
 - the voltage of the data logger battery (auxiliary)
- every 120 seconds (which is a preset value).

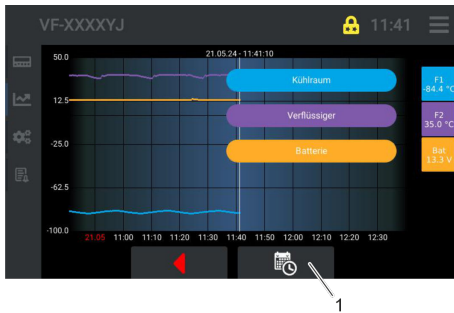

Fig. 19: Overview

Previous recordings from selectable time sequences can be loaded and viewed, see [Chapter 7.9 “Internal data logger and history function”](#) on page 84.

The data logger is equipped with a 1 GB industrial SD card which is sufficient to record data for a period of up to 2 years.

Once the memory is full, the oldest data is always overwritten first.

We recommend backing up the data every six months or more frequently, depending on the importance of the data, see [Chapter 7.7 “Data transfer via USB”](#) on page 82.

The data logger records additional data/information internally, such as

- Alarms
- Access to data and parameters
- Ambient temperatures

. This information can be viewed and evaluated on a PC using "ST-Studio" software.



Note: In order to edit data, the "ST-Studio" software must be installed on the corresponding device. The software is available free of charge from the manufacturer LAUDA. For more information, contact LAUDA Service.

4.9 Limit values USr user level, factory setting

A6	Alarm delay (device lid open)	Factory setting	60 seconds
A13	Lower limit 1 (absolute/relative) (low temperature)	Factory setting	-4.0K
A15	Upper limit 1 (absolute/relative) (over-temperature)	Factory setting	4.0K
A34	Alarm suppression time in the event of a power failure	Factory setting	5 s ¹
C11	Cold room temperature set point	Factory setting	Refer to the device card for the value
C25	Hysteresis, sensor F1	Factory setting	Refer to the device card for the value
H11	Offset correction, sensor F1	Factory setting	Refer to the device card for the value

¹ The value can be set from 0 to 3600 seconds, see [Chapter 5.5 “Setting the value for the alarm suppression time after a power failure”](#) on page 45.

The device card is located on the inside of the device front cover/panel, see [Chapter 4.2 “Structure of the Mobifreeze M 270 with and without the option for engagement recesses for forklift truck forks”](#) on page 26.

5 Before starting up

5.1 Installation



WARNING!
A sloping floor may cause the device to fall over/roll away

Injury, crushing, impacts

- Do not tilt the device.
- Position the device on an even, non-slip surface with a sufficient load carrying capacity.
- Only maneuver the device over non-slip surfaces with a maximum incline of 2 percent.
- To park the device, let go of the dead man's brake handle and apply both locking brakes.
- Do not place heavy objects on the device.



WARNING!
Danger of overpressure due to excessively high ambient temperatures

Fire, injury, leaking refrigerant

- Note the permissible ambient temperature and storage temperature, see ↗ Chapter 12.4 “Device data” on page 98.



WARNING!
Bursting of the cooling circuit

Fire, impacts, cutting, device damage

- Always maintain the permissible ambient conditions specified in the technical data.
- In small areas, maintain the ambient temperature by providing additional room ventilation or cooling.



WARNING! Formation of a flammable atmosphere

Fire

In the event of a refrigerant leak and/or damage to the device, note the following:

- Only certified specialized personnel are permitted to intervene in the refrigeration system and handle flammable refrigerants.
- Switch off the device and disconnect from the main power supply.
- Place/store the device in a well-ventilated location with no sources of ignition.
- Contact LAUDA Service.



NOTICE! Setting up the device

Equipment damage/material damage/malfunction

- The device must be at the permissible ambient temperature when started up. If not, the device must be acclimatized.

Always observe the following:

- Note the electromagnetic compatibility (EMC) requirements of the device. Refer to ↗ Chapter 1.3 “EMC requirements” on page 8 for more information.
- Check the mains cable for damage prior to starting up.
- The device can be operated at an ambient temperature in accordance with the technical data, see ↗ Chapter 12.4 “Device data” on page 98.
- During stationary or mobile operation, a higher ambient temperature has a negative effect on the device's cooling capacity or can cause the cooling system to switch off.
- Only use the device in an acclimatized state, see ambient temperature ↗ Chapter 12.4 “Device data” on page 98.
- Keep the device away from objects and walls and do not cover the ventilation openings.
- Move/push the device with the help of several people, if necessary.
- Check the charge level of the main battery. If the main battery of the ultra low temperature chest freezer reaches a “deep discharge” state, it must be activated again, see ↗ Chapter 5.10 “Wake up function” on page 50.



Refrigerant type and charge information is printed on the type plate or in the technical data.

5.2 Selecting the menu language



Fig. 20: Menu icon

1. Press the [Menu] icon.

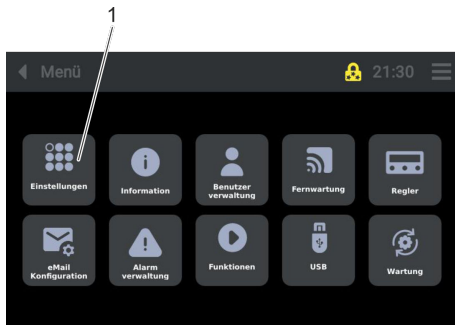

2. Press the [Settings] button (1).

Fig. 21: Settings



3. Press the [Language] button (2).
▶ The language selection screen opens.

Fig. 22: Settings_Language

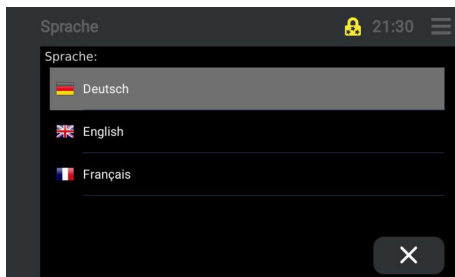

4. Select the language (German, English, French) on the Touch operating unit display.
▶ The display view switches to the controller view.
▶ After a few seconds, the display will switch to the selected language.

Fig. 23: Selecting a language

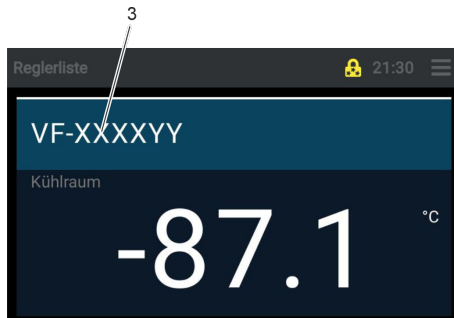

Fig. 24: Controller view

5.3 Setting the date and time



Fig. 25: Menu icon

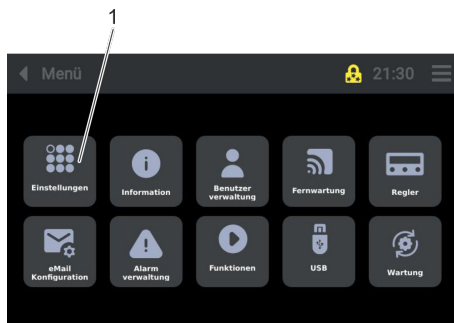

Fig. 26: Setup



Fig. 27: Setup_Date/Time

5. Press the [Type] button (3).
 - ▶ The Touch operating unit display switches to the "Home screen" view.
 - ▶ The selected language is active.

Set or change the date and time as follows.

1. Press the [Menu] icon.
2. Press the [Setup] button (1).
3. Press the [Date/Time] button (2).
 - ▶ The display view for changing the date/time opens.

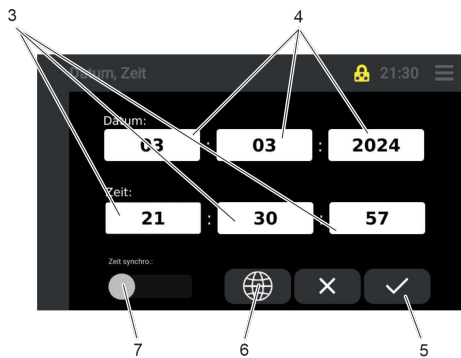

Fig. 28: Date/time

4. When individual buttons (3) and (4) are pressed, a numeric keypad appears.
 - ▶ Enter relevant values for the date and time.
5. Press the button (5) to confirm.
6. When the button (6) is pressed, a window displaying all the time zones opens.
 - ▶ Time zones can be selected/set without an Internet connection.
 - ▶ Select the time zone and confirm.
7. Pressing the button (7) synchronizes the time automatically.
 - ▶ In this case, the device must be connected to the Internet/Cloud.
 - ▶ The time has synchronized automatically.

5.4 Setting the temperature unit



Fig. 29: Menu icon

Set or change the temperature unit as follows:

1. Press the [Menu] icon.
2. Press the [Settings] button (1).

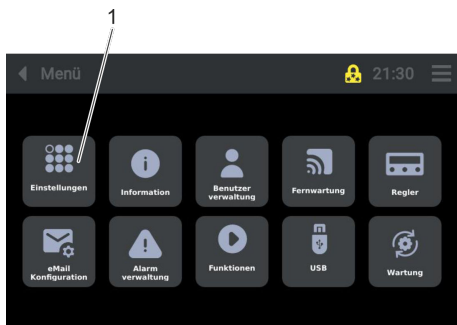

Fig. 30: Settings

3. Press the [Temperature Unit] button (2).
 - ▶ A new display view opens.

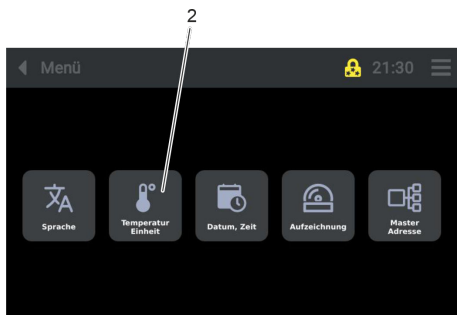

Fig. 31: Settings_Temperature-unit

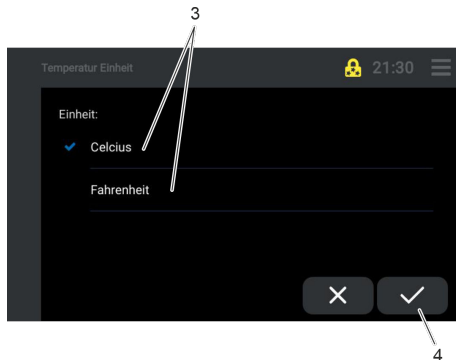

Fig. 32: Temperature unit

4. Select the required unit by pressing the corresponding button (3).
5. Press the button (4) to confirm.
 - ▶ The selected unit is active.

5.5 Setting the value for the alarm suppression time after a power failure

If the set alarm suppression time exceeds the factory-preset value, the "Power failure alarm suppression time" alarm (A 34) is triggered. Default value, see also ↗ Chapter 4.9 "Limit values USr user level, factory setting" on page 39.



Fig. 33: Menu icon

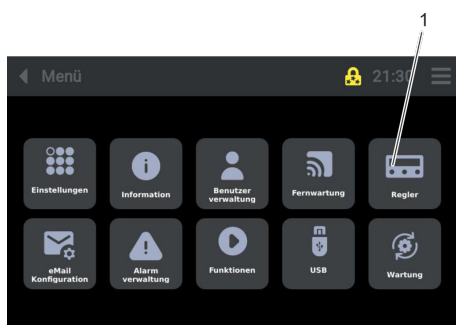

Fig. 34: Controller

1. Press the [Menu] icon on the operating unit.
2. Press the [Controller] button (1).

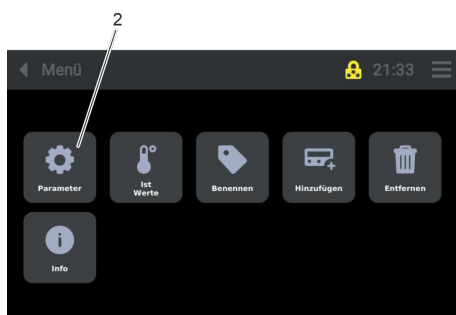

Fig. 35: Controller_Parameters

3. Press the [Parameters] button (2).

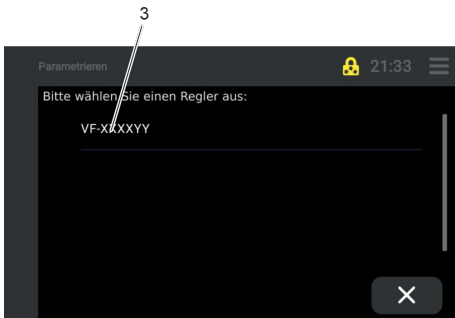

Fig. 36: Controller_Parameters_Controller_type

4. Select the controller by pressing the button (3).



Fig. 37: Alarms

5. Press the [A-alarms] button (4).



Fig. 38: Alarm message A34

6. Press the buttons (6) to scroll to the relevant alarm message.
7. Press the button (5) to select the alarm message (A34).
 - The window for modifying the limit value opens.

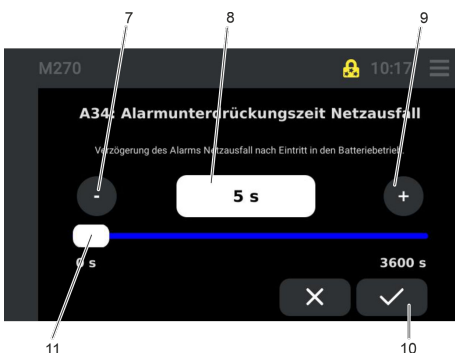

Fig. 39: Changing the alarm message A34_value

8. Set the required alarm suppression time (0 s (seconds) to 3600 s (seconds)) by moving the sliding switch (11), pressing the [+] (9) or [-] (7) buttons or entering the value directly (8).
9. Press the [Save] button (10).
 - The changed value is active.

5.6 Changing the record interval for the internal data logger

When the device is delivered, the default value is 120 seconds. Selecting a record interval that is too short will require the storage of a large amount of data and is therefore not recommended.

Change the record interval for the internal data logger as follows:



Fig. 40: Menu icon

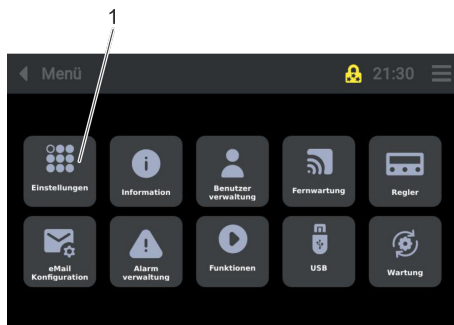

Fig. 41: Settings



Fig. 42: Settings_Records

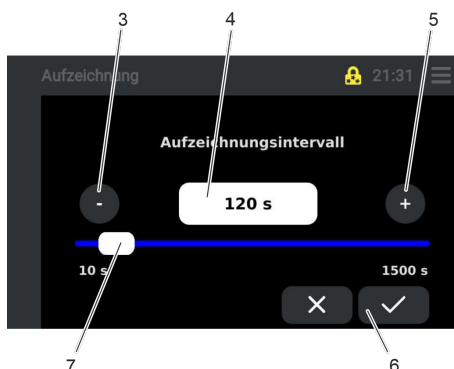

Fig. 43: Sample time

1. Press the [Menu] icon.

2. Press the [Settings] button (1).

3. Press the [Records] button (2).

► A new display view opens.

4. Set the relevant time (10 to 1500 seconds) by moving the slide button (7), pressing the [+] (5) and [-] (3) buttons, or entering the value directly (4).

5. Press the button (6) to confirm.

► The selected record interval is active.

5.7 Changing the plant name

Change the plant name as follows:



Fig. 44: Menu icon

1. Press the [Menu] icon.
2. Press the [Information] button (1).

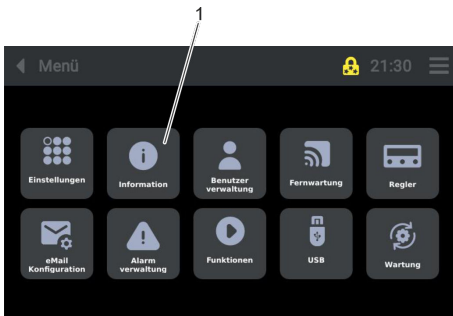

Fig. 45: Information

3. Press the [Plant Name] button (2).
 - ▶ A keyboard appears.

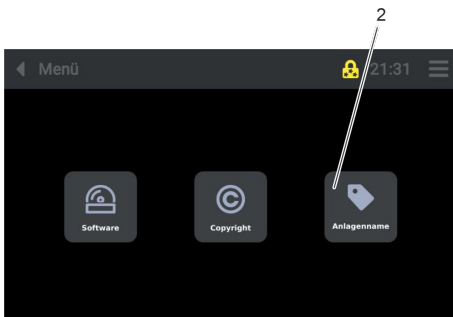

Fig. 46: Information_Plant_name

4. Change the plant name and press the button (3) to save.
 - ▶ The new plant name is active.



Fig. 47: Keyboard

5.8 Displaying software information



Fig. 48: Menu icon

Display the software information as follows:

1. Press the [Menu] icon.

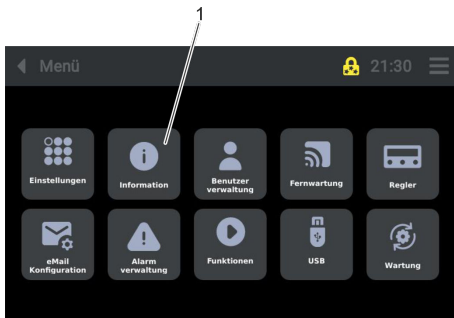

Fig. 49: Information

2. Press the [Information] button (1).



Fig. 50: Information_Software

3. Press the [Software] button (2).

▶ A list of software information appears.

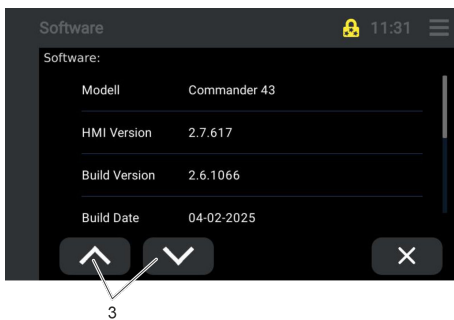

Fig. 51: Software

4. Scroll through the software list using the buttons (3).

5.9 Displaying copyright information

Display the copyright information as follows:

1. Press the [Menu] icon.



Fig. 52: Menu icon

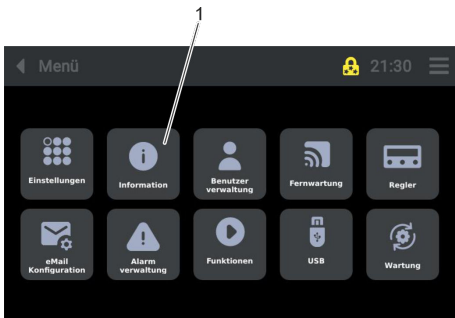

Fig. 53: Information

2. Press the [Information] button (1).



Fig. 54: Information_Copyright

3. Press the [Copyright] button (2).
 - ▶ A list of copyright information appears.

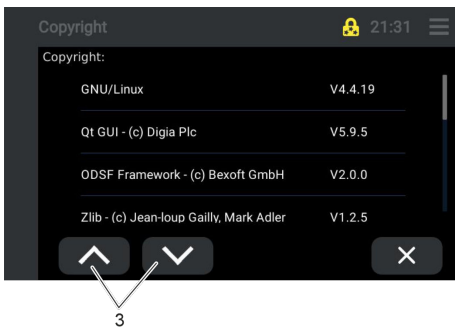

Fig. 55: Copyright

4. Scroll through the copyright list using the buttons (3).

5.10 Wake up function



DANGER!
Touching live parts

Electric shock

Before installing modules or intervening in the device:

- Disconnect the device from the mains power.
- Switch off the main battery.
- Only permitted by certified specialized personnel.
- Allow the device to cool down.

A deeply discharged main battery can be reactivated using a "wake up" technique.

- Personnel: ■ Electrician
- Protective equipment: ■ Protective gloves
■ Safety shoes



Fig. 56: Mains switch

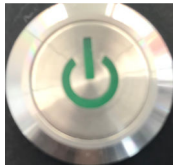

Fig. 57: Main battery switch

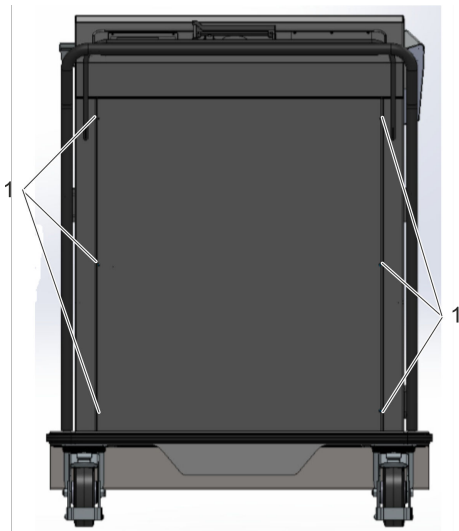

Fig. 58: Front view of the ultra low temperature chest freezer

1. Switch off the mains switch (position "O") on the ultra low temperature chest freezer.

2. Switch off the main battery switch.

3. Unscrew the six screw connections (1) and remove the front cover/panel from the ultra low temperature chest freezer.



2

4. Set the main switch (3) of the inverter (2) to position "O" (4).

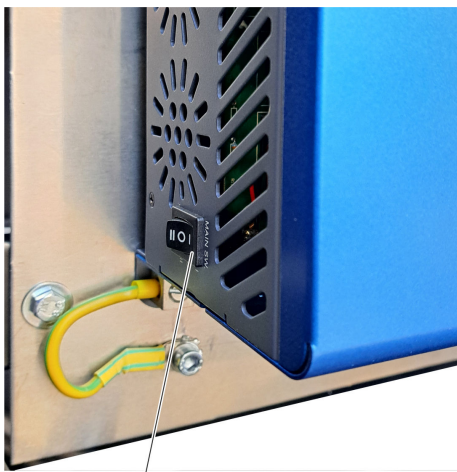

3

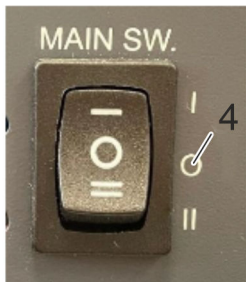

Fig. 59: Inverter with main switch

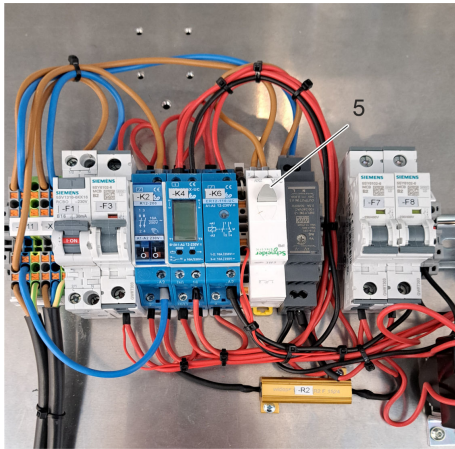

Fig. 60: Button on the installation board



Fig. 61: Mains switch

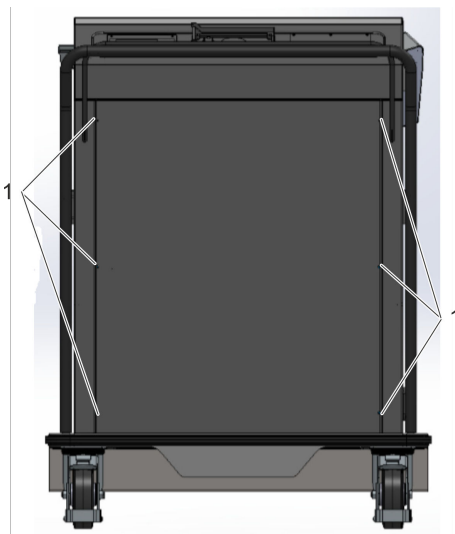

Fig. 62: Front view of the ultra low temperature chest freezer

5. Connect the device to the mains power before pressing the button (5) on the installation board. Then press and hold the button (5).

6. After about 5 seconds, switch on the mains switch (position "I").
 - ▶ The power unit then supplies 24 volts to the battery terminals and automatically starts the charging process for the inverter.
7. Release the button (5) on the installation board approximately 10 seconds after the inverter has been switched on.
8. Switch on the main battery.
 - ▶ The main battery starts charging.
 - ▶ Once the main battery is fully charged, the battery monitor will synchronize.
9. Switch off the mains switch (position "O").
10. Switch off the main battery switch.
11. Set the main switch (3) of the inverter (2) to position "I".
12. Refit the six screw connections (1) to the cover/panel on the front of the ultra low temperature chest freezer.
 - ▶ The ultra low temperature chest freezer is ready for use.

5.11 Installing modules



DANGER!
Touching live parts

Electric shock

Before installing modules or intervening in the device:

- Disconnect the device from the mains power.
- Switch off the main battery.
- Only permitted by certified specialized personnel.
- Allow the device to cool down.

When installing modules, such as an external monitoring system, the device must be switched off, see ↪ Chapter 6.2 “Switching the device on and off” on page 59, and unplugged from the mains power. Furthermore, the main battery must be switched off, see ↪ Chapter 4.5.2 “Main battery switch” on page 35.

Connections:

Two connection terminals F7 and F8 (1 and 2) with an unregulated nominal voltage of 25.6 V DC are available for connecting a monitoring system.

Connection F7 (1) can be used for both mains and battery operation. The battery charge level must be 20 percent or more.

Connection F8 (2) can only be used for mains operation.

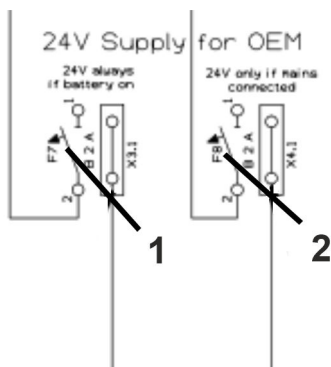



Fig. 63: Connections

Table 2: Electrical nominal values:

	Output voltage	Max. output voltage	Max output current
F7/F8	24 V (+/- 20%)	28.8 V	2 A

- Personnel: ■ Electrician
- Protective equipment: ■ Safety shoes
 ■ Protective gloves

1. Disconnect the ultra low temperature chest freezer from the power supply by pulling out the mains plug.
2. Switch off the main battery at the main battery switch (1).

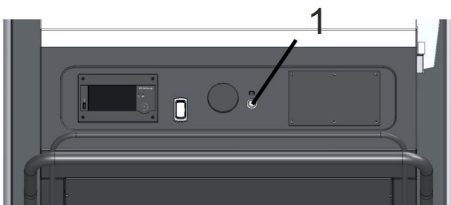

Fig. 64: Main battery switch

3. Unscrew the six screw connections and remove the device front cover/panel.
 - ▶ Caution, risk of short circuit!



CAUTION!
Risk of short circuit

Material damage

For work on live components, please note the following:

Work may only be performed by qualified electricians.

A voltage of approximately 25.6 V is present at point 2 (K5) and at other open terminals.

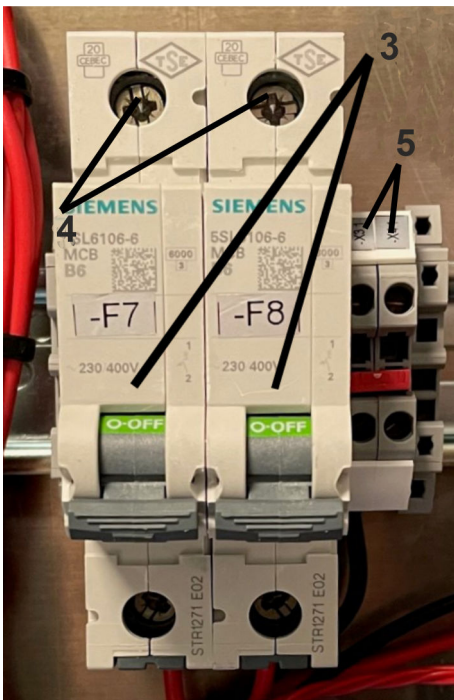
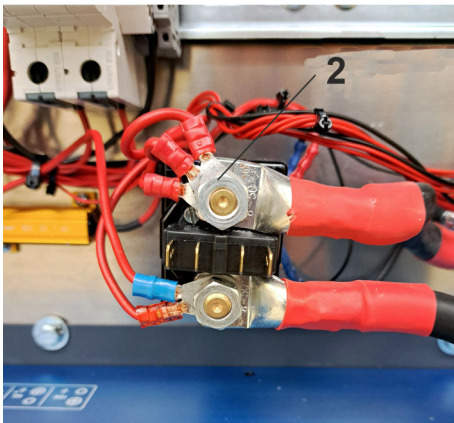

4. Check that the circuit breakers (F7 and F8) are set to the "OFF" position (3).
5. Connect components to terminals F7 and F8 (4) and X3.1 and X4.1 (5), ground connection.

Fig. 65: F7 and F8, X3.1 and X4.1

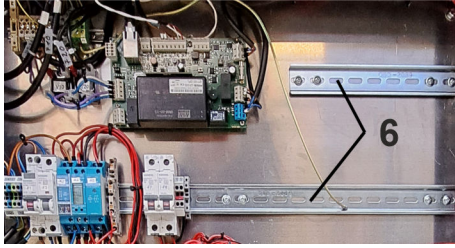

Fig. 66: Profile rail

6. The customer's own systems can be mounted/connected to the profile rails (6).
7. Set circuit breakers (F7 and F8) to the "ON" position.
8. Refit the device front cover/panel by securing the six screw connections.
 - ▶ Put the ultra low temperature chest freezer into operation.

6 Commissioning

6.1 Establishing a mains connection



DANGER! Transport damage

Electric shock

- Closely inspect the device for transport damage prior to commissioning!
- Never operate a device that has sustained transport damage!



DANGER! Risk of short circuit due to failure to observe the acclimatization time

Electric shock

- Allow a "cold" device to first acclimatize to the ambient temperature.
- Wait until the device reaches the ambient temperature before connecting it to the power supply and starting it up.
- Ambient temperatures, see chapter "Technical data".



WARNING! Contact with voltage conductors due to faulty mains cable and/or mains plug

Electric shock

- Before using the mains cable and mains plug, check that they are in perfect condition.
- Never use a faulty mains cable or mains plug to power the device.
- The mains cable and mains plug must not come into contact with any refrigerated surfaces on the device, neither during operation nor after switching off.



CAUTION! Tripping over mains cables

Injuries, personal injury

Retract the mains cable when not in use.

- When operating with mains power, lay the mains cable in such a way that it does not pose a danger
- Check the mains cable every six months.



NOTICE! Use of impermissible mains voltage or mains frequency

Device damage

- Compare the type plate with the available mains voltage and mains frequency.
- Only connect to the power supply if the specifications are compliant.
- When operating the device from the mains, the power supply must be properly fitted with a protective earth conductor (PE).
- Local regulations must be observed.

Please note the following:

- Note for electric installation on site:
 - The devices must be protected with a 16-ampere circuit breaker, fitted during installation (mains fuse on site).
 - Refer to the type plate or technical data for connection values.
- Only connect the device to power sockets with a protective earth conductor (PE).
- Only use the retractable power cable with mains plug for the power supply.
- Always pull out the cable completely before operating the device.
- Operate the device according to local regulations.

6.2 Switching the device on and off

Switching on the device



Fig. 67: Mains switch

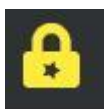

Fig. 68: User icon

1. Set the mains switch to the "I" position, see ↗ Chapter 4.5.1 "Mains switch" on page 34.
 - ▶ Once the device has started up (after approximately 5 seconds), the overtemperature alarm [Tmax 1] is shown on the Touch operating unit display and the alarm signal sounds.

Note:

Switching the refrigeration controller on/off is only possible from the "User" user profile onward, see ↗ Chapter 6.4 "Selecting a user profile" on page 62 and ↗ Chapter 6.3 "Defining user profiles" on page 61.

2. Acknowledge the alarm message on the Touch operating unit display, ↗ Chapter 7.8 "Acknowledging an alarm" on page 83.



Fig. 69: ON/OFF icon

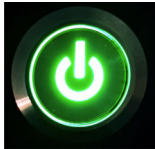

Fig. 70: Main battery switch pressed

3. Press the [ON/OFF] icon on the Touch operating unit, see ↗ Chapter 4.3 “Touch operating unit” on page 30.

- ▶ The device is switched on.

Note:

For mains-independent operation, the main battery must also be switched on at the main battery switch.

4. Set the main battery switch to the “[I]” position, see ↗ Chapter 4.5.2 “Main battery switch” on page 35.

- ▶ Ultra low temperature chest freezer and main battery are switched on.



When using the ultra low temperature device for long periods of continuous operation, it makes sense to leave the mains switch and battery switch in the (I) position.

As a result, the switch positions do not have to be changed.

The mains plug is pulled out to interrupt the mains power supply and commence mobile operation. The mains plug can then be connected again at any time to resume mains operation.

Switching off the device

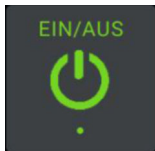

Fig. 71: ON/OFF icon



Fig. 72: Mains switch

1. Press the [ON/OFF] tile on the Touch operating unit, see ↗ Chapter 4.3 “Touch operating unit” on page 30.

2. Set the mains switch to the [O] position, see ↗ Chapter 4.5.1 “Mains switch” on page 34.

- ▶ This will disconnect the mains power supply. However, the device remains switched on when the main battery switch is set to the (I) position. The device operates in battery mode and the main battery switch lights up green.

If the device is completely disconnected from the power supply, the main battery must also be actively switched off.

3. Set the battery switch to the [O] position, see ↗ Chapter 4.5.2 “Main battery switch” on page 35.

- ▶ The light on the main battery switch goes out and the device is no longer operational. The display remains illuminated for a short while.

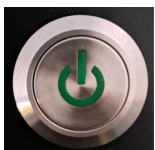

Fig. 73: Main battery switch



When the device is switched off, the main battery switch should always be switched off to prevent the main battery from actively discharging.

Instructions for switching off:

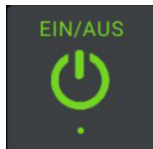

Fig. 74: ON/OFF icon

1. If you intend to switch off the device for longer periods, press the [ON/OFF] icon on the Touch operating unit.
 - ▶ [OFF] appears on the display
2. Set the mains switch to the "O" position, see ↗ Chapter 4.5.1 "Mains switch" on page 34.

If the device is switched off at the mains switch and the controller is still active, the "power failure" alarm is triggered and the device records the temperature for approximately 35 hours, powered by the battery of the internal data logger.

6.3 Defining user profiles

"Guest" user profile



Fig. 75: Guest icon

The device is started with the "Guest" user ID.

All data relevant to device operation can be accessed in this level.

The refrigeration controller cannot be switched on or off in this user level.

Settings cannot be changed in this level.

The default password is "Guest".

"User" user profile



Fig. 76: User icon

Individuals logging in with the "User" user ID can change settings such as the set point of the cooling chamber temperature or the alarm delay for the door.

The default password is "User".

"Service" user profile



Fig. 77: Service icon

Under the "Service" user ID, the operator/user can change more settings than in the "User" level including changing parameters or the limit of set point temperatures as well as transferring data via USB, for example.

The default password is "Service".

"Admin 1" user profile



Fig. 78: Admin 1 icon

All settings can be modified under the "Admin 1" user ID, such as those required to integrate the device into the operator's IT landscape.

The default password is "Admin 1".



The "Admin 1" user profile must not be deleted.

It is the customer's master key for the device and is also used, for example, to change the permissions of subordinate user profiles or to create other user profiles.

"ADMIN" user profile



Fig. 79: Admin icon



The "ADMIN" user profile is reserved for access by a LAUDA plant technician. Only LAUDA knows the password. The "ADMIN" user profile may not be deleted under any circumstances.

6.4 Selecting a user profile



Fig. 80: Login and user profile display

1. Press the [Login and user profile display] icon on the operating unit.
 - ▶ The display switches to the "Login" overview.
2. Select the required user profile (Admin 1, Guest, Service or User).
 - ▶ A keyboard appears.

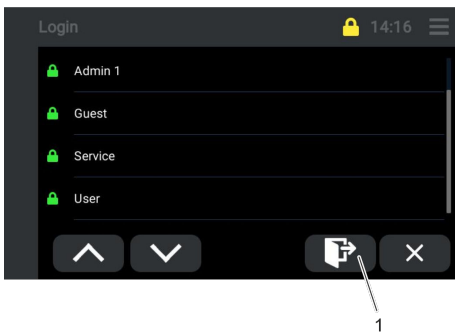

Fig. 81: User profiles



Fig. 82: Keyboard

3. Use the keyboard to enter the password for the selected user profile.
4. Press the [Save] button (2).
 - ▶ The selected user profile is active.
5. It is also possible to log out a selected user by pressing button (1).

For more information about the different user profiles, see [Chapter 6.3 "Defining user profiles"](#) on page 61.

6.5 Changing the user profile password

In a user profile, only the passwords for this level and the levels below can be changed.

Only "Admin 1" can change all passwords.

The number of stars in the yellow padlock on the Touch operating unit display indicates which user profile is currently active.

User profile type	Number of stars in the padlock
ADMIN	3 This access is reserved for a LAUDA plant technician.
Admin 1	3
Service	2
User	1
Guest	-



Fig. 83: Menu icon

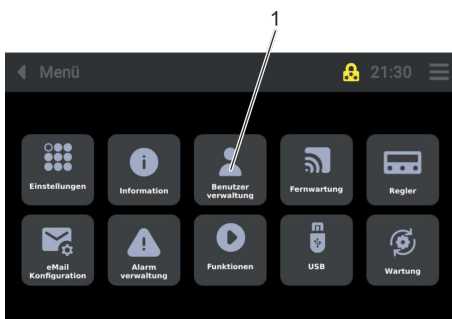

Fig. 84: User management

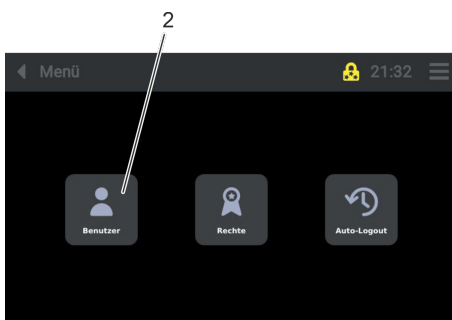

Fig. 85: User_management_User

1. Press the [Menu] icon on the operating unit.
 - ▶ The menu overview opens.
2. Press the [User management] button (1).
3. Press the [User] button (2).
 - ▶ The "User" overview opens.

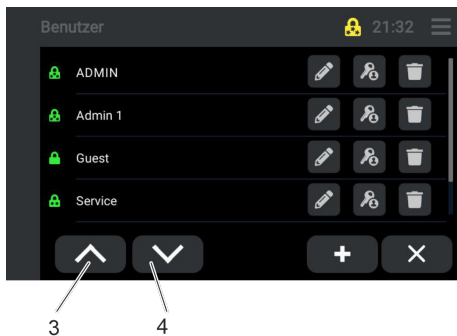

Fig. 86: User overview

4. Press the button (4) to scroll down in the user overview and press the button (3) to scroll up in the menu.

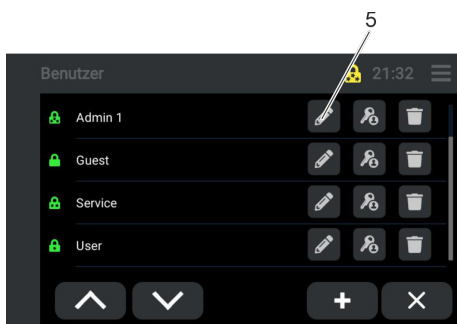

Fig. 87: User overview

5. Select the user. Press the [Edit] button (5).
 - ▶ A keyboard appears.



Fig. 88: Keyboard

6. Enter the "new" password using the keyboard and save by pressing the button (6).
 - ▶ The password has been changed.
7. Pressing the [Previous level] button (7) changes the view.
 - ▶ The display switches to the "Home screen" view.

6.6 Creating a new user name



Fig. 89: Menu icon

1. Press the [Menu] icon on the operating unit.
 - ▶ The menu overview opens.

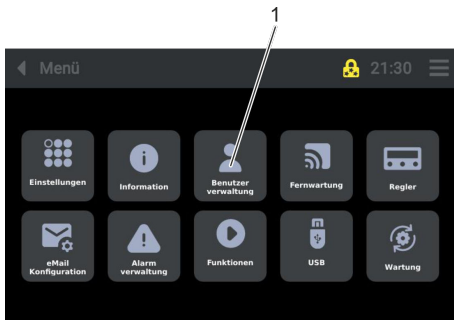

Fig. 90: User management

2. Press the [User management] button (1).

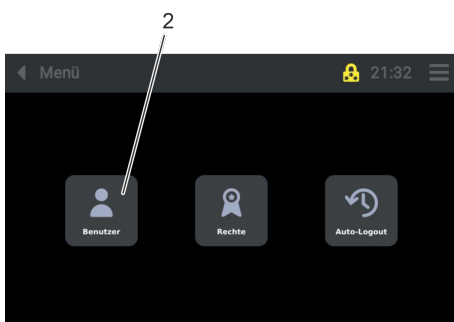

Fig. 91: User_management_User

3. Press the [User] button (2).
 - ▶ The "User" overview opens.

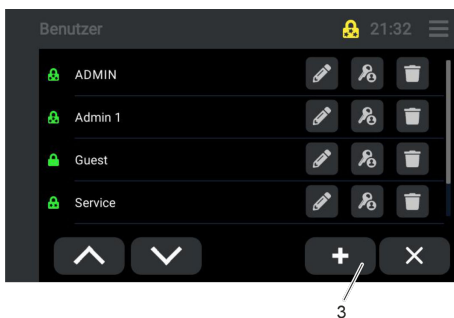

Fig. 92: User overview

4. Press the button (3).
 - ▶ A keyboard appears.

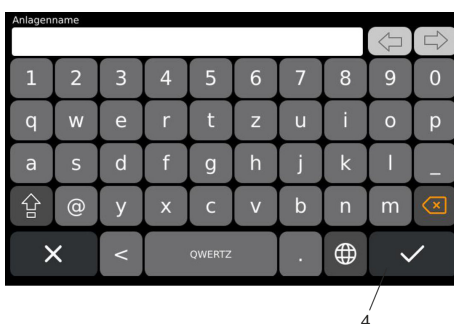

Fig. 93: Keyboard

5. Enter the "new" user name using the keyboard and save by pressing the button (4).
 - ▶ The new user name has been created.
 - ▶ Now the user profile rights must be configured, see [Chapter 6.7](#) "Configuring user profile rights" on page 65.

6.7 Configuring user profile rights

The "Configure user rights" function can only be activated from the "Admin 1" user profile.



Fig. 94: Menu icon

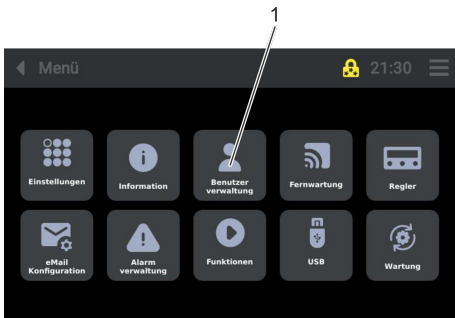

Fig. 95: User management

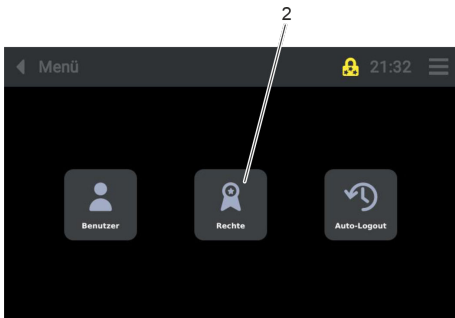

Fig. 96: User_management_Rights

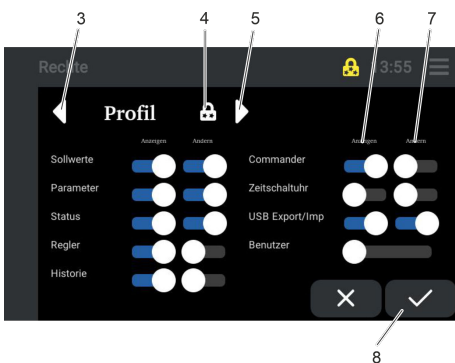

Fig. 97: Profile

1. Press the [Menu] icon on the operating unit.
2. Press the [User management] button (1).
3. Press the [Rights] button (2).
 - ▶ The "Rights" overview opens.
4. You can navigate through the various created profiles by pressing button (3) or (5).
 - ▶ The display (4) shows which user profile is currently active.
5. Profile rights can be configured/changed by moving the Display (6) and/or Change (7) slide buttons.
6. Press the [Save] button (8).
 - ▶ The profile rights for the current user profile (4) are saved.

6.7.1 Explanations of user rights

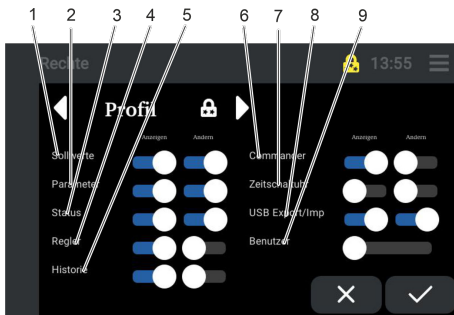

Fig. 98: Profile rights

1	Setpoints	Displaying/changing the setpoint for the cold room temperature.
2	Parameter	Displaying/changing the parameters stored on the controller(s).
3	Status	Displaying/changing the current operating status of the device on the user interface.
4	Controller	Displaying/changing controllers connected to the operating unit (commander).
5	History	Displaying/changing the history, such as the temperature history of the cold room and condenser as well as the voltage of the auxiliary battery.
6	Commander	Displaying/changing the commander settings (operating unit), including settings, user management, remote maintenance, email configuration, alarm management and maintenance.
7	Clock timer	Displaying/changing functions. Timers (scenes) can be configured under this item.
8	USB export/import	Exporting and importing history data, configuration files for the commander (operating unit) and controller parameters (control unit).
9	User	Displaying/changing user profiles and their rights.

6.8 Activating auto logout

To prevent unwanted access to the device controller, the "Auto Logout function" can be activated to protect the Touch control element.

When the "Auto logout function" is activated, the Touch control element automatically reverts back to the "Guest profile". This means that it is no longer possible to adjust the temperature or switch off the refrigeration controller.

The "Auto logout" function can only be activated from the "Service" and "Admin 1" user profiles, see also ↪ Chapter 6.3 "Defining user profiles" on page 61.



Fig. 99: Menu icon

1. Press the [Menu] icon on the operating unit.



2. Press the [User management] button (1).

Fig. 100: User management

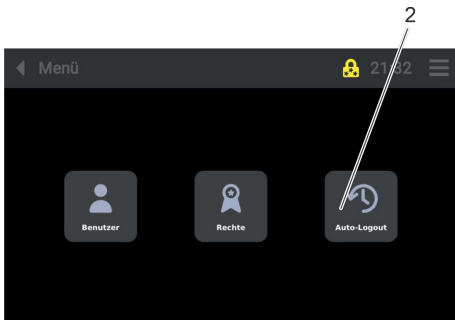

3. Press the [Auto logout] button (2).

► The "Auto logout" overview opens.

Fig. 101: User_management_Auto_logout

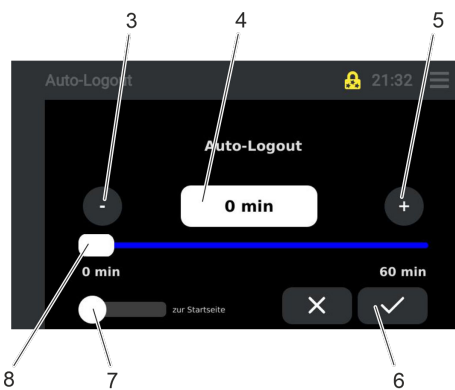

4. Set the relevant time (1 to 60 minutes) by moving the slide button (8), pressing the [+] (5) and [-] (3) buttons, or entering the value directly (4).

5. Press the [Save] button (6).

6. After moving the "Back to home page" slider button (7), the display view changes to the "Controller" view once the set time has elapsed.

► "Auto logout" is activated for the preset time.

Fig. 102: Auto logout

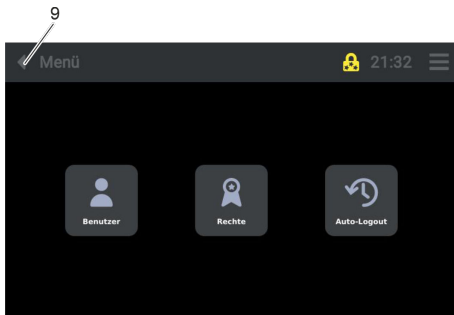

Fig. 103: Menu

- When the button (9) is pressed, the display reverts back to the "Controller" view.

6.9 Selecting and displaying control curves



Fig. 104: Data logger icon

- Press the [Data logger] icon on the Touch operating unit.
 - The control curve overview opens.

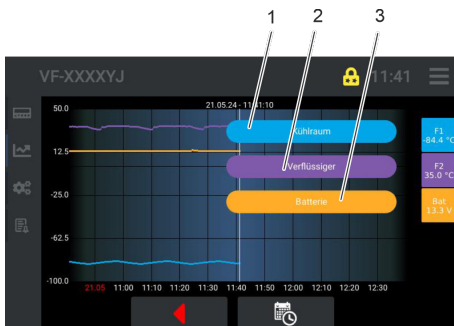

Fig. 105: Control curves – Control curve screen

Briefly tap button [F1] (1), [F2] (2) or [Bat] (3) to display their designation to the left of the buttons.

All three control curves are selected by default.

To display only one control curve, the other control curves must be deactivated.

To deactivate a control curve, press and hold the corresponding symbol for approximately 3 seconds. The symbol will then turn white and the control curve will disappear.

To activate the control curve, press and hold the deactivated white symbol for approximately 3 seconds until it changes back to its original color.

- Blue (F1) = Cold room (refrigeration compartment temperature)
- Violet (F2) = Condenser (condenser temperature)
- Orange (Bat) = Battery (voltage of the internal auxiliary battery)

6.10 Setting alarm limit values

For additional information on "Alarms, warnings and errors", see also the "Faults" chapter, [Chapter 9.2 "Alarms, warnings and errors"](#) on page 91.

6.10.1 Setting the alarm delay limit value for the device lid

When the device lid is opened, a timer starts. If the preset delay time is exceeded, the device lid alarm is triggered. For information on the factory preset value for the alarm delay, see also [Chapter 4.9 "Limit values USr user level, factory setting"](#) on page 39.



Fig. 106: Menu icon

- Press the [Menu] icon on the operating unit.

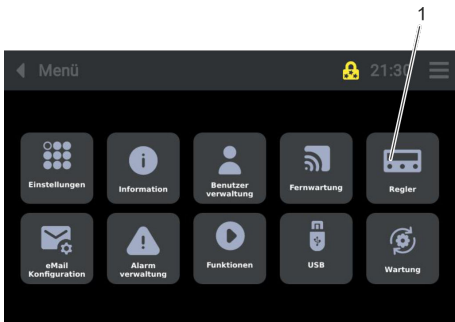

Fig. 107: Controller

2. Press the [Controller] button (1).

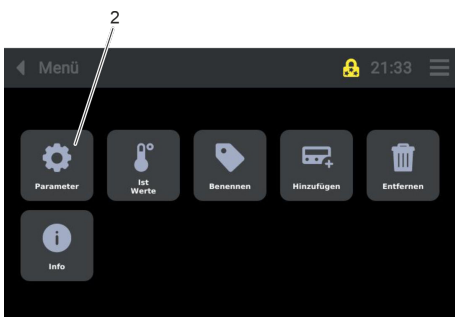

Fig. 108: Controller_Parameters

3. Press the [Parameters] button (2).

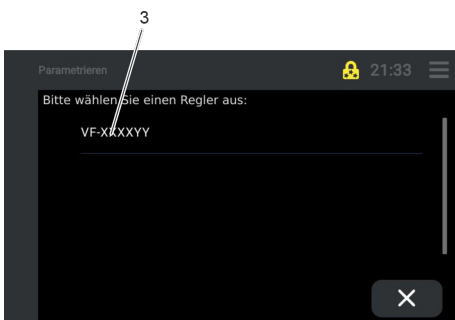

Fig. 109: Controller_Parameters_Controller_type

4. Select the controller by pressing the button (3).



Fig. 110: Alarms

5. Press the [A-alarms] button (4).

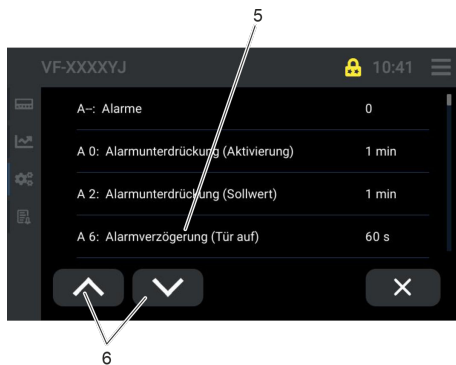

Fig. 111: Alarm message A6

6. Press the buttons (6) to scroll to the relevant alarm message.
7. Press the button (5) to select the alarm message (A6).
 - ▶ The window for modifying the alarm delay opens.

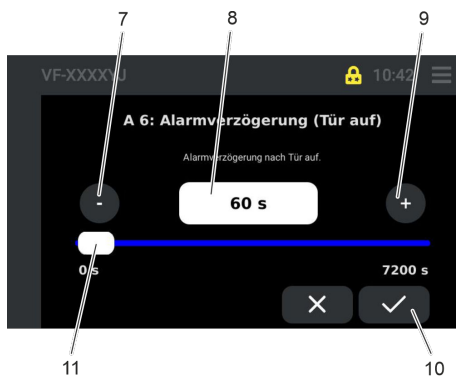

Fig. 112: Alarm message A6_Changing the setting value

8. Set the required time (0 to 7200 seconds) by moving the sliding switch (11), pressing the [+] (9) or [-] (7) button, or entering a value directly (8).
9. Press the [Save] button (10).
 - ▶ The new device lid time delay is active.

6.10.2 Setting a limit value for the low temperature alarm

If the cold room temperature falls below the factory preset lower limit value (absolute/relative), the low temperature alarm is triggered. Default value, see also Chapter 4.9 “Limit values USr user level, factory setting” on page 39.



Fig. 113: Menu icon

1. Press the [Menu] icon on the operating unit.

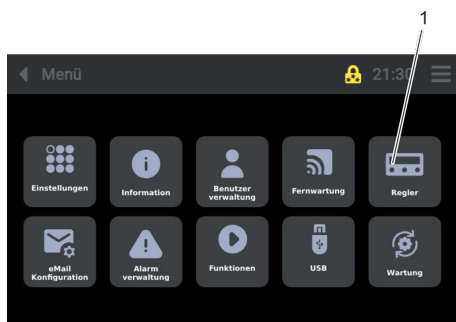

Fig. 114: Controller

2. Press the [Controller] button (1).

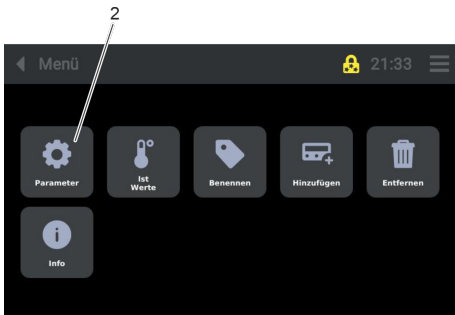

Fig. 115: Controller_Parameters

3. Press the [Parameters] button (2).

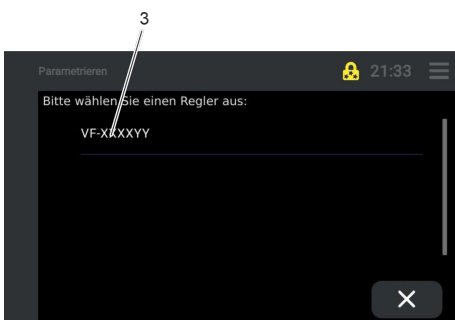

Fig. 116: Controller_Parameters_Controller_type

4. Select the controller by pressing the button (3).



Fig. 117: Alarms

5. Press the [A-alarms] button (4).



Fig. 118: Alarm message A13

6. Press the buttons (6) to scroll to the relevant alarm message.
7. Press the button (5) to select the alarm message (A15).
 - ▶ The window for modifying the limit value opens.

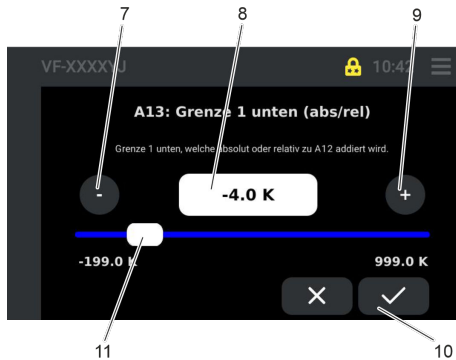

Fig. 119: Alarm message A13_Changing the limit value

8. Set the relevant temperature difference (-199 K to 999 K) by moving the slide button (11), pressing the [+] (9) and [-] (7) buttons, or entering the value directly (8).
9. Press the [Save] button (10).
 - ▶ The modified upper limit value (absolute/relative) is active.

6.10.3 Setting a limit value for the overtemperature alarm

If the cold room temperature exceeds the factory preset upper limit value (absolute/relative), the "overtemperature" alarm is triggered. Default value, see also ↪ Chapter 4.9 "Limit values USr user level, factory setting" on page 39.



Fig. 120: Menu icon

1. Press the [Menu] icon on the operating unit.

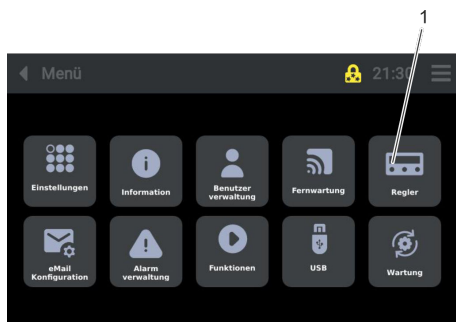

Fig. 121: Controller

2. Press the [Controller] button (1).

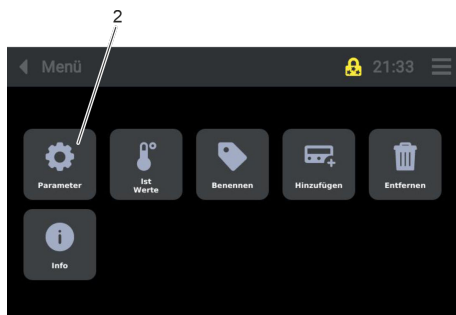

Fig. 122: Controller_Parameters

3. Press the [Parameters] button (2).

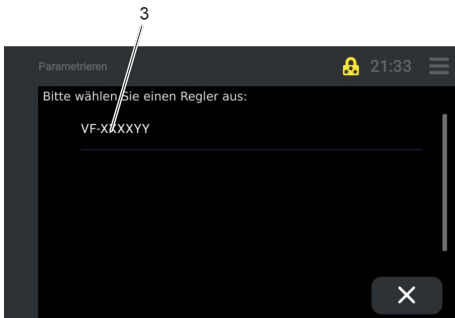

Fig. 123: Controller_Parameters_Controller_type

4. Select the controller by pressing the button (3).



Fig. 124: Alarms

5. Press the [A-alarms] button (4).

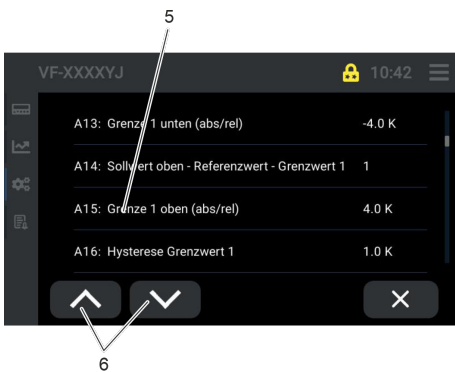

Fig. 125: Alarm message A15

6. Press the buttons (6) to scroll to the relevant alarm message.
7. Press the button (5) to select the alarm message (A15).
 - The window for modifying the limit value opens.



Fig. 126: Alarm message A15_Changing the limit value

8. Set the relevant temperature difference (-199 K to 999 K) by moving the slide button (11), pressing the [+] (9) and [-] (7) buttons, or entering the value directly (8).
The temperature difference value must be "positive" (+).
9. Press the [Save] button (10).
 - The modified upper limit value (absolute/relative) is active.

7 Operation

7.1 Safety information

7.1.1 General safety instructions



DANGER!

Fault, mechanical damage, electrical overload or manufacturing fault

Explosion, fire, release of toxic gases

- Protect the battery system from damage.
- In the event of a fault, immediately disconnect the device from the mains power supply.
- If necessary, use a suitable extinguishing agent to extinguish a LiFePO₄ battery fire.
- Contact LAUDA Service.



If the LiFePO₄ battery catches fire, use suitable fire extinguishers to extinguish the fire. These fire extinguishers should be designed specifically to extinguish battery fires. They can contain classic extinguishing agents such as CO₂ (powder or normal foam), or can be gel fire extinguishers or special lithium-X extinguishers.



DANGER!

Short circuit

Electric shock

- Prevent liquids from entering the electrical components inside the device.
- Protect the device from rain and/or splash water.
- If the device meets the specified protection level and protection class, the device can be moved outdoors for a short time, even in the rain.



WARNING!

Storage of dangerous goods

Personal injury, risk of explosion

- Do not store:
 - Acids and alkalis that can attack materials
 - Hazardous substances that emit harmful fumes
 - Substances that are highly flammable and/or explosive



WARNING!
Risk of mechanical damage to refrigerant circuit

Leaking flammable refrigerant generates an explosive atmosphere

Explosion, burns, fire

- Ventilate the room thoroughly without delay.
- During this period, do not operate any switches on the device or anywhere else in the room.
- Do not ignite flames or sparks and refrain from smoking.



CAUTION!
Risk of mechanical damage to refrigerant circuit

Hazard to health through inhalation (TLV values exceeded)

- Ventilate the room thoroughly without delay.
- During this period, do not operate any switches on the device or anywhere else in the room.
- Do not ignite flames or sparks and refrain from smoking.

7.1.2 Securing a device transported in a vehicle



WARNING!
Uncontrolled device movement during transport

Danger of injury, device damage

- Secure the load properly to prevent it from moving or sliding.
- Activate the locking casters.
- Activate the dead man's brake. The dead man's brake handle must not be secured in the pulled position.
- The load must not come into contact with the outer walls of the vehicle or any other cargo items.

7.1.3 Pushing/moving the device



WARNING!
Operating error when pushing, rollover hazard due to casters

Risk of injury from rolling over, impacts

- Do not roll the device over your feet or other parts of your body.
- Move the device carefully, ask several people to help, if necessary.
- Wear safety shoes.
- Avoid collisions with other people and objects.
- Avoid foreseeable misuse, see [Chapter 1.7](#) “Foreseeable misuse” on page 9.

7.1.4 Operating the device in fluctuating ambient temperatures



DANGER!
Condensation on electronics

Electric shock

- Minimize the time that the device spends in cold ambient temperatures.
- Ambient temperatures, see chapter “Technical data”.

7.2 Adjustment of the cooling chamber temperature set point



Fig. 127: Touch operating unit

After the device is switched on at the mains switch, see [Chapter 4.5.1](#) “Mains switch” on page 34, and on the Touch operating unit, see [Chapter 4.3](#) “Touch operating unit” on page 30, the display shows the current temperature (2) in the cold room.

The temperature controller switches the compressors on.

The cooling process starts to bring the temperature in the cooling chamber up to the set point.

The cooling chamber temperature indicator remains red until the set point is reached. When the set point has been reached, the indicator turns white. If there is a fault on the device, the indicator switches back to red.

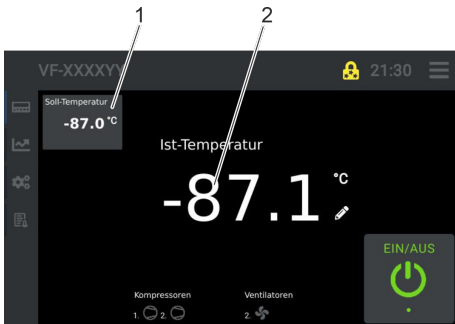

Fig. 128: Cooling chamber temperature set point icon

1. Press the [Cold room temperature set point] button (1).
 - ▶ The window for setting the "Cooling chamber temperature set point" opens.

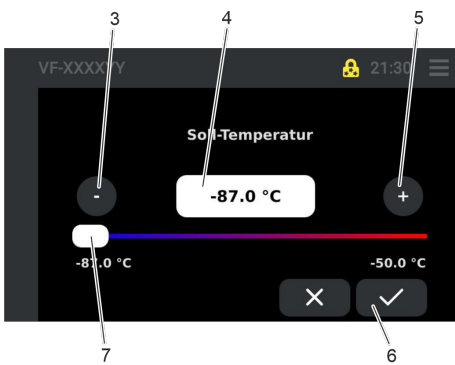

Fig. 129: Set point setting

2. Set the relevant cold room temperature by moving the slide button (7), pressing the [-] (3) and [+] (5) buttons, or entering the value directly (4).
3. Press the [Save] button (6).
 - ▶ The set point has been set and saved.

7.3 Storing and retrieving refrigerated goods

<p>CAUTION! Missing protective equipment</p>	
	<p>Personal injury, risk of frostbite</p> <p>If the temperature in the refrigeration compartment is low, take the following measures:</p> <ul style="list-style-type: none"> ● Always wear suitable cold protection gloves when storing and retrieving refrigerated goods. ● Arms must also be covered.
<p>CAUTION! Individuals shorter than 1.70 m are not permitted to operate or set up the device</p>	
	<p>Personal injury, ergonomic impairment</p> <ul style="list-style-type: none"> ● Use a step-up stool when storing and retrieving refrigerated goods.

- Personnel:
- Specialized personnel
 - Instructed person
- Protective equipment:
- Cold protection gloves
 - Safety shoes

- Always wear safety gloves that protect the hands from cold temperatures when storing and retrieving refrigerated goods. Arms must also be covered.
- Depending on your height, it may be necessary to use a step-up stool to load and unload refrigerated goods.
- Only store refrigerated goods that meet the requirements for intended use, see ↪ Chapter 1.5 “Intended use” on page 8.
- Do not store refrigerated goods that do not meet the requirements for intended use, see ↪ Chapter 1.6 “Unintended use” on page 9.

7.4 Switching between mains and battery operation

	<p>CAUTION! Tripping over mains cables</p>
	<p>Injuries, personal injury</p>
	<p>Retract the mains cable when not in use.</p> <ul style="list-style-type: none"> ● When operating with mains power, lay the mains cable in such a way that it does not pose a danger ● Check the mains cable every six months.

If you wish to transport the ultra low temperature chest freezer to another location, proceed as follows:

1. Disconnect the mains cable from the power socket and allow the cable to wind up.
 - ▶ The device switches automatically to battery operation and continues to cool
 - ▶ provided that the battery switch is set to "On".
2. After arriving at the installation destination, pull out the mains cable completely and connect to the power socket.
 - ▶ The device continues to cool and the main battery is charged,
 - ▶ provided that the mains switch is set to "On".

7.5 Dead man's brake handle



WARNING!
A sloping floor may cause the device to fall over/roll away

Injury, crushing, impacts

- Do not tilt the device.
- Position the device on an even, non-slip surface with a sufficient load carrying capacity.
- Only maneuver the device over non-slip surfaces with a maximum incline of 2 percent.
- To park the device, let go of the dead man's brake handle and apply both locking brakes.
- Do not place heavy objects on the device.

Design of the dead man's brake handle, see ↗ Chapter 4.5.4 “Dead man's brake with handle” on page 35.

Application limits for the dead man's brake, see ↗ Chapter 1.10 “Ambient conditions and operating conditions” on page 10.

1. Position the device in the installation location.
2. Let go of the dead man's brake handles.
3. Apply the locking brakes.

7.6 Alarm management



Fig. 130: Menu icon

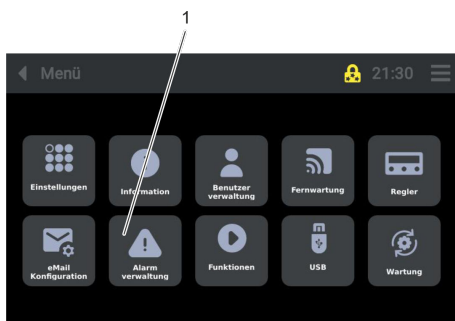

Fig. 131: Alarm management

1. Press the [Menu] icon.
2. Press the [Alarm management] button (1).

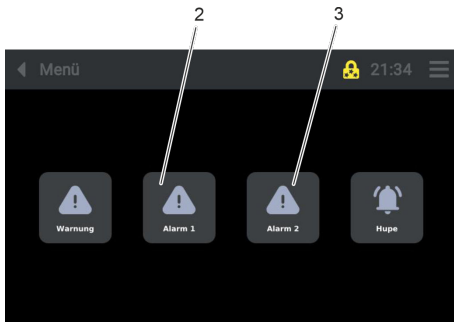

Fig. 132: Alarm_management_Alarm 1 or Alarm 2

3. Select the [Alarm 1] (2) or [Alarm 2] (3) button.
 - ▶ The display switches to the "Alarm 1" or "Alarm 2" view.

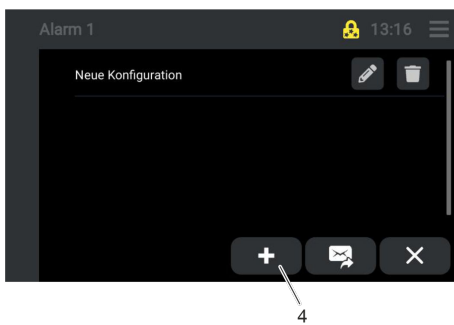

Fig. 133: Alarm 1, add

4. Press the [Add] button (4).
 - ▶ The display switches to the "Controller" view.

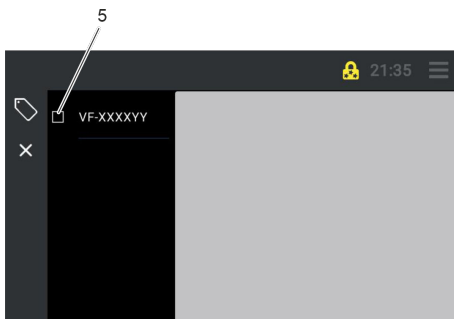

Fig. 134: Alarm - Controller

5. Select the "Type" (5).

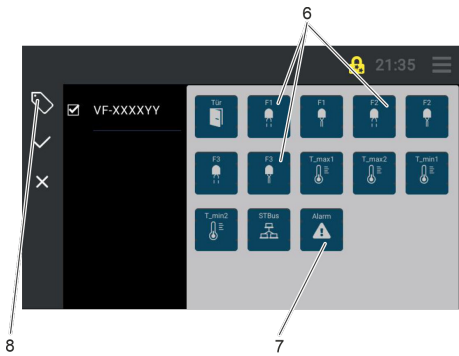

Fig. 135: Alarm_New configuration

6. It is possible to select individual "alarms" (6) or to select all alarms by pressing the [Alarm] button (7).

- Door = door alarm
- F1 = Cable break on sensor F1
- F1 = Short circuit on sensor F1
- F2 = Cable break on sensor F2
- F2 = Short circuit on sensor F2
- F3 = Cable break on sensor F3 - not assigned
- F3 = Short circuit on sensor F3 - not assigned
- T_max 1 = Temperature value is greater than A15
- T_max 2 = Temperature value is greater than A25
- T_max 1 = Temperature value is lower than A13
- T_max 2 = Temperature value is lower than A23
- STBus = Communication error
- Alarm = List of all alarms

7. Press the [Enter] button (8).

- ▶ A keyboard appears for inputting values.

8. Enter a name and press the button (9) to save.

- ▶ The display view opens with the created name.



Fig. 136: Keyboard

7.7 Data transfer via USB

Data can only be transferred via USB if the "Service" or "Admin 1" user profile is selected.



Note: In order to edit data, the "ST-Studio" software must be installed on the corresponding device. The software is available free of charge from the manufacturer LAUDA. For more information, contact LAUDA Service.

When exporting data using a USB stick, please note the following:

- Use a USB stick with 16 GB or 32 GB of storage (manufacturer recommendation). The storage on the USB stick used cannot exceed 64 GB.
- Perform standard formatting, do not carry out fast formatting.
- Use format "FAT 32".

1. Press the [Menu] icon.



Fig. 137: Menu icon

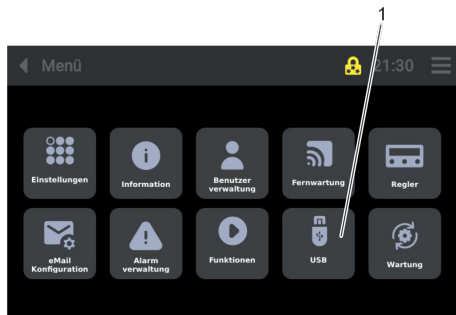

Fig. 138: USB

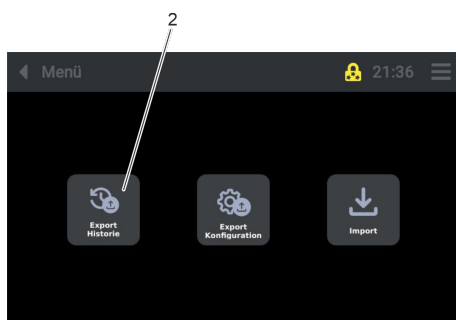

Fig. 139: USB_Export history

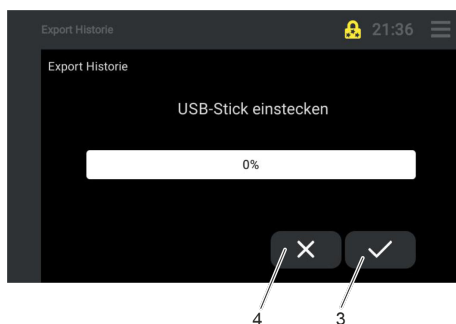

Fig. 140: Inserting the USB stick

7.8 Acknowledging an alarm

Disabling the acoustic alarm and rectifying the cause of the alarm



Fig. 141: Alarm icon

2. Press the [USB] button (1).

3. Press the [Export History] button (2).

4. Insert the USB stick.

▶ The system recognizes the USB stick.

5. Press the save icon (3).

▶ Data is transferred to the USB stick.

6. When the data transfer is complete, press the [Cancel] button (4).

▶ Data is loaded onto the USB stick.

▶ Remove the USB stick.

In the event of a malfunction, an alarm is triggered.

When an alarm is triggered, an acoustic alarm sounds and a visual alarm appears in an alarm window.

1. Acknowledge the alarm in the alarm window.

▶ The alarm screen closes.

▶ A red alarm symbol is displayed at the top of the Touch operating unit.

▶ The alarm symbol disappears automatically once the alarm has been cleared, see also List of faults ↗ Chapter 9.2 “Alarms, warnings and errors” on page 91.

7.9 Internal data logger and history function



Fig. 142: Data logger icon

1. Press the [Data logger, history] icon.
 - ▶ "Controller 1" view opens.
 - ▶ The chronological progression of all measured values is displayed.
 - ▶ Touch gestures can be used to scroll and zoom.

Note: Pressing the [red arrow symbol] returns the display to the current time.

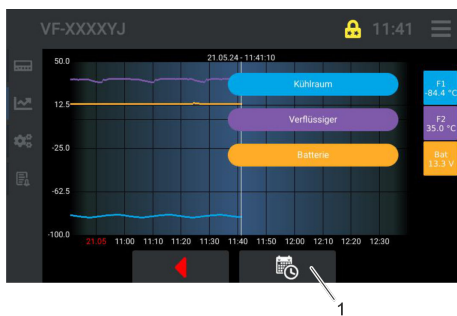
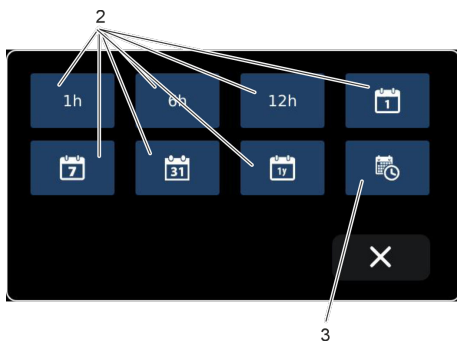

Fig. 143: Data logger



2. Press the button (1).
 - ▶ An overview of time periods opens.
3. Select the required time period by pressing the relevant button (2).
 - ▶ The temperature profile is displayed.
4. To retrieve past records, press the [History] button (3).
 - ▶ A window for setting the "from" / "to" date opens.

Fig. 144: Selecting a time period

1h = 1 hour
 6h = 6 hours
 12h = 12 hours
 1 t = 1 day
 7 t = 7 days
 31 t = 31 days
 1y = 1 year

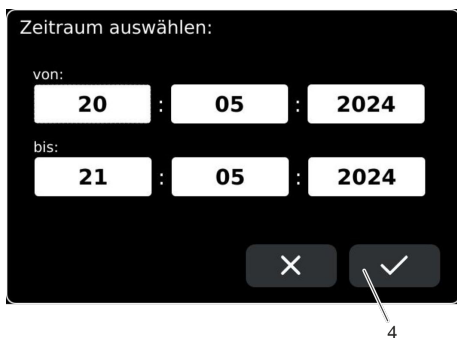

5. Select the required date/time period using the keyboard that appears, then press the button (4) to confirm.
 - ▶ The temperature profile for the selected period is displayed.

Fig. 145: Time periods from/to

7.10 Device operation with safety cooling

If the power supply for the mains supply and main battery fails, the set temperature can be maintained using dry ice (solid carbon dioxide (CO₂)).



DANGER!

Gas displaces atmospheric oxygen or negatively affects oxygen absorption

Danger of asphyxia

- Ventilate rooms adequately.

Personnel: ■ Refrigeration specialist

Protective equipment: ■ Cold protection gloves

■ Safety glasses

1. Open the refrigeration compartment device cover.
2. Fill with dry ice.
3. Close the refrigeration compartment device cover.



The phase transition of solid carbon dioxide into gaseous carbon dioxide creates gage pressure in the device's refrigeration compartment. In order to dissipate this gage pressure in a controlled manner, the device has a pressure relief valve with a maximum trigger pressure of 0.2 bar.

8 Maintenance

8.1 General safety instructions



DANGER! Contact with live or moving parts

Electric shock, impacts, cutting, crushing

- Before any maintenance work is performed, the device must be disconnected from the mains power and the main battery switch must be set to the [O] position.
- Only skilled certified personnel are permitted to perform repairs.



DANGER! Incorrect handling

Fire

- Only skilled personnel are permitted to perform service and repair work.
- Repair work on the refrigeration system may only be performed by skilled, certified personnel who are trained to handle flammable refrigerants.



WARNING! Uncontrolled leaking of refrigerant

Fire

- Never dispose of a cooling circuit that is still pressurized.
- Disposal tasks may only be performed by skilled, certified personnel who are trained to handle flammable refrigerants.



WARNING! Retracting spring hinge on the refrigeration compartment lid

Crushing of limbs

- Open the refrigeration compartment lid carefully.
- Wear personal protective equipment such as safety gloves.



WARNING!
Risk of mechanical damage to refrigerant circuit

Explosion, fire

- Only trained personnel permitted to perform service work.
- Ventilate the room thoroughly without delay.
- During this period, do not operate any switches on the device or anywhere else in the room.
- Do not ignite flames or sparks and refrain from smoking.



CAUTION!
Contact with hot or cold device parts and accessories

Scalding, hot or cold burns

- Allow device parts and accessories to reach room temperature before touching.

8.2 Maintenance plan

Interval	Maintenance task
Daily	Inspect the external condition of the device.
	Remove any frost from the lid seal.
Weekly	Clean the device, see ↪ Chapter 8.3 “Cleaning the device” on page 87
Monthly	Keep the condenser fins free of dust, see ↪ Chapter 8.4 “Cleaning the condenser fins” on page 88
As necessary	Defrost the refrigeration compartment, ↪ Chapter 8.5 “Defrosting the refrigeration compartment” on page 89
	Inspect the device for damage and stability (function test/check the braking force of the dead man’s brake handle) after transport, whenever necessary or annually at the latest

8.3 Cleaning the device



DANGER!
Liquid ingress during cleaning

Electric shock

- Clean with a damp cloth to prevent liquids from entering the electrical components.
- Avoid accumulations of liquid.
- Turn off the mains switch.
- Disconnect the device from the power supply before starting repair or cleaning work.

Personnel: ■ Instructed person

Protective equipment: ■ Protective gloves

Please also note the following:

- Only use water and detergent to clean the Touch control element and other surfaces. Do not use acetone or solvent as these substances will permanently damage the plastic surfaces.
- Ensure that the device is decontaminated after coming into contact with hazardous materials.
- It is forbidden to use decontaminants or cleaning agents that may react with parts of the device or materials contained in those parts and potentially pose a **hazard**.
- We recommend using ethanol as a decontaminant. If you are unsure whether decontaminants or cleaning agents are compatible with device parts or the materials contained in those parts, please contact LAUDA Service.

8.4 Cleaning the condenser fins

In order to ensure that the device operates efficiently, the condenser fins must be cleaned monthly or more often, if necessary, in dirty ambient conditions.



WARNING!
Incorrect handling, refrigerant leaks

Fire, cutting

- Only open the ventilation grid when cleaning.
- Use suitable materials for cleaning such as a soft brush, a vacuum cleaner or compressed air.



CAUTION!
Compressors and pressure lines reach temperatures of approximately 75 degrees

Burns

- Switch off the device and disconnect from the main power supply.
- Set the main switch and battery switch to the [O] position.
- Allow device parts and accessories to reach room temperature before touching.

Personnel: ■ Instructed person

Protective equipment: ■ Safety glasses
■ Protective gloves

1. Switch off the device at the mains switch and battery switch, see ↗ Chapter 6.2 “Switching the device on and off” on page 59 and ↗ Chapter 4.5.2 “Main battery switch” on page 35.
2. Disconnect the mains cable from the power supply, and wind up.
3. Open the ventilation grid to access the condenser.
4. Clean the fins on the condenser with a brush or use a vacuum cleaner or compressed air to clean the fins. Do not apply pressure to, or damage, the fins.
5. Refit the ventilation grid.
6. Connect the device to the mains power supply, see ↗ Chapter 6.1 “Establishing a mains connection” on page 58.

8.5 Defrosting the refrigeration compartment

Defrost the refrigeration compartment of the device whenever necessary, or if there is heavy freezing.



WARNING!
Refrigerant leaks

Fire, device damage

- Allow the ice in the refrigeration compartment to defrost on its own.
- Do not place heating devices in the refrigeration compartment.
- Do not use sharp objects or chip/scrape off the ice.

Personnel: ■ Instructed person

Protective equipment: ■ Cold protection gloves

1. Switch off the device and the main battery, see ↗ Chapter 6.2 “Switching the device on and off” on page 59 and ↗ Chapter 4.5.2 “Main battery switch” on page 35.
2. Pull out the mains plug from the power socket and wind up the mains cable.



NOTICE!

Make sure that liquids cannot enter the cable connections or the electrical components inside the device.

3. Open the refrigeration compartment on the device.
4. Remove the contents from the refrigeration compartment.
5. Allow the ice to defrost.

6. Continuously remove the melt water from the refrigeration compartment.
7. Allow the refrigeration compartment to dry or wipe dry with a soft cloth.
8. Once the refrigeration compartment is free of ice and dry, reconnect the device to the mains power supply, see ↪ Chapter 6.1 “Establishing a mains connection” on page 58 and ↪ Chapter 6.2 “Switching the device on and off” on page 59.

9 Faults

9.1 Calculation errors during synchronization of the battery monitor and manual synchronization

Calculation errors during synchronization of the battery monitor

Another condition for synchronizing the battery monitor is that the electrical charge drawn from the main battery must match the electrical charge supplied after the charging process. Occasionally, chargers can switch to maintenance mode a little too early, thereby preventing automatic synchronization. The sensitivity for this comparison can be modified in the battery monitor parameters.

If the battery monitor does not display 100 percent or "Full" after a complete charging process, manual synchronization must be performed one time. Please note that the mains plug must be connected to a power socket and the main switch set to active in order to charge the main battery. If the battery is not fully charged after at least eight hours, it must be ensured that before manual synchronization, the voltage displayed on the battery monitor is 27.5 volts \pm 0.1 volts and the charging current is 0 amperes.

Please note:



Manual synchronization may only be performed under the conditions described above, otherwise, there is a risk of the main battery deep discharging due to discrepancies between the battery monitor's charge level indicator and the actual battery charge level.

Manually synchronizing the battery monitor

To manually synchronize the main battery, press and hold both arrow keys [10] and [12] (see chapter ↗ Chapter 4.4 "Main battery monitor" on page 33) on the battery monitor simultaneously for 3 seconds. As a result, the battery monitor's charge level jumps to "Full" one time.

For more information on the main battery monitor, see ↗ Chapter 4.4 "Main battery monitor" on page 33.

9.2 Alarms, warnings and errors

Additional display	Error text/fault text	Message with acoustic alarm	Acknowledge acoustic alarm	Description/meaning/comments	Corrective action
ErrL	Short circuit on sensor F1	Yes	Yes	Ohmic measured value of sensor 1 too low	Have sensor replaced by LAUDA Service.
ErrH	Cable break on sensor F1	Yes	Yes	Ohmic measured value of sensor 1 too high	Have sensor replaced by LAUDA Service.
ErrL	Short circuit on sensor F2	Yes	Yes	Ohmic measured value of sensor 2 too low	Have sensor replaced by LAUDA Service.
ErrH	Cable break on sensor F2	Yes	Yes	Ohmic measured value of sensor 2 too high	Have sensor replaced by LAUDA Service.
	Battery unsuitable (data logger battery)	Yes	Yes	Battery is unsuitable/battery values do not comply with the preset default values	LAUDA Contact Service and install the battery recommended by the manufacturer.

Additional display	Error text/fault text	Message with acoustic alarm	Acknowledge acoustic alarm	Description/meaning/comments	Corrective action
	Battery faulty or missing (data logger battery)	Yes	Yes	Battery defective or missing/ battery missing according to q44	LAUDA Contact Service and install the battery recommended by the manufacturer.
	Battery operation/power failure (main battery)	Yes	Yes	No mains power and no power supply from the main battery.	Check whether the mains switch is on and the mains cable is plugged in. In battery mode: Check whether the battery switch is on. If the main battery is discharged: Plug in the mains plug and turn on the mains switch to charge the main battery.
	Battery voltage low (data logger battery)	Yes	Yes	Battery voltage low/output in battery mode	Check the battery and, if necessary, have the recommended battery replaced by LAUDA Service.
	Door contact	Yes	Yes	Door contact error/door open	Close door/cover.
	Limit value 1, low value	Yes	Yes	Temperature value is lower than A13/freely adjustable monitoring of process variables	Device too cold. The device may not yet be filled with refrigerated goods. Adjust the limit value. Goods stored in the device may be colder than the device's set point temperature. Acknowledge the alarm and wait until the refrigerated goods have reached the device's set point temperature. The second stage compressor may not switch off. Contact LAUDA service.

Additional display	Error text/fault text	Message with acoustic alarm	Acknowledge acoustic alarm	Description/meaning/comments	Corrective action
	Limit value 1, high value	Yes	Yes	Temperature value is higher than A15/freely adjustable monitoring of process variables	Device too warm. Device may still be in the cooling phase. Wait until the set point is reached. The ambient temperature may be too high. Allow to cool. Condenser may be contaminated. Vacuum off the condenser or blow clean with compressed air (do not blow clean near smoke detectors as the disturbed dust may trigger the fire alarm). The device may be positioned too close to a wall. Ensure that the device is positioned 15 cm away from the wall. Warm exhaust air from another device may be blowing into the device's condenser. The device and motor compartment may be positioned next to a heater or heating pipes. Move the device to another location. The ventilator fan may have failed. Contact LAUDA service. Have alarms such as the power failure or door contact alarms been previously triggered? Rectify the fault.
	Limit value 2, low value	Yes	Yes	Temperature value is lower than A23/freely adjustable monitoring of process variables	Device is located in an environment that is too cold. Operation is no longer possible. Choose a warmer installation location or ensure a sufficiently high room temperature.
	Limit value 2, high value	Yes	Yes	Temperature value is higher than A25/freely adjustable monitoring of process variables	Ambient temperature too high and/or the condenser is heavily contaminated. Clean the condenser and wait for 10 minutes before commissioning the device. Description: A fault in the condenser causes the compressors to continuously switch on and off against high pressure which may end up destroying the compressors.

Additional display	Error text/fault text	Message with acoustic alarm	Acknowledge acoustic alarm	Description/meaning/comments	Corrective action
	EP0 Program error	Yes	Yes	Flash error, repair possible/possibly switch on/off (min. 10 seconds), otherwise see EP2	If necessary, replace the controller board. Contact LAUDA service.
	EP1 Parameter error	Yes	Yes	Parameter configuration incorrect/correct parameters, otherwise EP2	If necessary, replace the controller board. Contact LAUDA service.
	EP2 Memory error	Yes	Yes	Flash error irreparable/reinstall software	If necessary, replace the controller board. Contact LAUDA service.
F90	Controller not found	Yes	Yes		LAUDA Contact Service.
F92	Internal communication issue	Yes	Yes	Possible switch on/off (min. 10 sec.)	LAUDA Contact Service.
F93	Memory error in operating unit/controller	Yes	Yes		LAUDA Contact Service.

10 Decommissioning

10.1 General information on decommissioning

Information on decommissioning

- Remove refrigerated goods from the refrigeration compartment, see ↪ Chapter 7.3 “Storing and retrieving refrigerated goods” on page 78.
- Download data from the device, see ↪ Chapter 7.7 “Data transfer via USB” on page 82.
- Check the charge level of the main battery and charge if necessary, see ↪ Chapter 10.2 “Main battery after decommissioning” on page 95.
- Switch off the device, see ↪ Chapter 6.2 “Switching the device on and off” on page 59.
- Wind up the mains cable completely.
- Defrost the refrigeration compartment, see ↪ Chapter 8.5 “Defrosting the refrigeration compartment” on page 89.
- Clean the device, see ↪ Chapter 8.3 “Cleaning the device” on page 87.
- Note the storage temperature of the device, see ↪ Chapter 12.4 “Device data” on page 98.

10.2 Main battery after decommissioning



NOTICE!

Damage to the lithium iron phosphate battery due to deep discharge

- When not in use/decommissioned, charge the battery to between 70 and 100 percent.
- Check the charge level after 4 months at the latest and recharge, if necessary.

If the device is decommissioned or not in use, note the following:

- main battery must be charged 70 to 100 percent, ideally 90 percent.
- Switch off the main battery at the main battery switch, see ↪ Chapter 4.5.2 “Main battery switch” on page 35.
- Check the battery charge level every 4 months and recharge, if necessary.
- Observe the storage temperature (decommissioned device) of 5 to 43 °C, see ↪ Chapter 12.4 “Device data” on page 98.

11 Disposal

11.1 Disposing of refrigerant



DANGER!
Incorrect handling

Fire

- Disposal work on the refrigeration system may only be performed by skilled, certified personnel who are trained to handle flammable refrigerants.



WARNING!
Uncontrolled leaking of refrigerant

Fire

- Never dispose of a cooling circuit that is still pressurized.
- Disposal tasks may only be performed by skilled, certified personnel who are trained to handle flammable refrigerants.



Refrigerant type and charge information is printed on the type plate or in the technical data.

11.2 Disposing of the main battery



NOTICE!
Environmental damage caused by incorrect disposal

- Dispose of the main battery and electronic components correctly in accordance with national regulations for LiFePO₄ batteries or electronic components.

11.3 Device disposal



The following applies for EU member states: The device must be disposed of according to Directive 2012/19/EU (WEEE Waste of Electrical and Electronic Equipment).

11.4 Disposing of packaging

The following applies for EU member states: Disposal of the packaging must proceed according to regulation 94/62/EC.

12 Technical data



The device sound pressure level is below 70 dB. According to EC Directive 2006/42/EC the sound pressure level of the devices is therefore not specified further.

12.1 Touch operating unit data

Designation/details	Description/value	Unit
Display type	TFT color display, touch screen	---
Display size	4.3	Inches
Display resolution	480x272	Pixels

12.2 Main battery monitor data

Designation/details	Description or tolerance data	Unit
Display type	LCD, illuminated	---
Display resolution	Voltage: 0 to 35	+/- 0.01
	Current: 0 to 200	+/- 0.1
	Ampere hours: 0 to 200	+/- 0.1
	Charge level: 0 to 100	+/- 0.1
	Remaining time: 0 to 24 hours	+/- 1 minute
		-

12.3 Main battery and auxiliary battery data

Main battery

Designation/details	Value/designation	Unit
Main battery information	Main battery monitor	---
Main battery type	LiFePO4	---
Nominal capacity	100	Ah
Energy content	2560	Wh
Nominal battery voltage	25.6	V
Cycle lifetime	≥3000 at 90 percent DoD	---
Battery undervoltage cutoff	20 percent charge or 23.8 V	---
Battery display "Discharge alarm off"	Charge level above 30 percent	---
Manufacturer	Liontron	---

Auxiliary battery

Designation/details	Value/designation	Unit
Manufacturer	Long	---

12.4 Device data

Designation/details	Value/designation	Unit
External dimensions (WxDxH)	1473x933x1214	mm
Internal dimensions of refrigeration compartment (WxDxH)	900x600x500	mm
Refrigeration compartment volume	270	Liter
Empty weight	325	kg
Maximum payload	100	kg
Temperature range	-50 to -86	°C
Temperature stability (over time)	+/- 3 K at -80 °C	---
Maximum transport gradient	2 (1)	%
Temperature setting/temperature display	Touch operating unit	---
Mains voltage	230	V
Length of retractable cable	6	m
Power supply connector type	Safety plug (CEE7/7) for Switzerland: SEV1011, SEV5934/2 T23 CH	---
Mains voltage deviation	+/- 10	%
Frequency	50	Hz
Main fuse on site	T 16	A
Overvoltage category	II	---
Pollution degree	2	---
Protection level/protection class	IP 22	---
Power consumption at maximum cooling capacity while simultaneously charging battery	2.3	kW
Power consumption at maximum cooling capacity with fully charged battery	0.9	kW
Power consumption at -80°C with fully charged battery	0.5	kW
Power consumption on standby while battery is charging	1.0	kW
Maximum geographical altitude above sea level	2000	m
Maximum relative humidity	80% at 28°C	---
Ambient temperature	SN-ST (5 - 37)(2)	°C

Designation/details	Value/designation	Unit
Storage temperature (decommissioned device)	5 to 43	°C
Transport temperature (decommissioned device)	-20 to 43	°C

(1) = value valid for moving the ultra low temperature chest freezer manually, not for transport by heavy-duty truck or industrial truck.

(2) = see table below

Overview of ambient temperature:	
Pre-cooled device	5°C–37°C
Device in cooling mode	5°C–27°C
Pre-cooled device in operation with device protective cover and spacer	5°C–30°C
Device in operation with device protective cover and spacer	5°C–27°C

12.5 Refrigerant and filling charge

The device contains flammable refrigerants.

Table 3: R 290, 1st stage

	M 270	Unit
Refrigerant	R 290	---
Maximum filling weight	0.145	kg

Table 4: R 170, 2nd stage

	M 270	Unit
Refrigerant	R 170	---
Maximum filling weight	0.068	kg

13 General

13.1 Copyright

This manual is protected by copyright and only meant for internal use by purchasers.

The relinquishment of this manual to third parties, copying in any way whatsoever – even in the form of excerpts – and the utilization and/or conveyance of its content are not allowed, except for internal purposes, without written approval from the manufacturer.

Violation of this may obligate the violator to the payment of damages. Other claims reserved.

We point out that the designations and brand names of the respective companies used in the manual are generally subject to trademark, brand and patent protection.

13.2 Technical changes

The manufacturer reserves the right to make technical modifications to the device.

13.3 Warranty conditions

LAUDA guarantees a standard 12-month manufacturer's warranty from the date of the device's purchase.

13.4 Contact LAUDA

Contact LAUDA Service in the following cases:

- Troubleshooting
- Technical questions
- Ordering accessories and spare parts

Please contact our sales department for questions relating to your specific application.

Contact information

LAUDA Service

Phone: +49 (0)9343 503-350

Email: service@lauda.de

13.5 Declaration of Conformity



EU-KONFORMITÄTSERKLÄRUNG

Hersteller: LAUDA DR. R. WOBSEY GMBH & CO. KG
Schulze-Delitzsch-Straße 4+5, 30938 Burgwedel, Deutschland

Hiermit erklären wir in alleiniger Verantwortung, dass die nachfolgend bezeichneten Maschinen

Produktlinie: Mobifreeze **Seriennummer:** ab 5230000001

Type: M 270

aufgrund ihrer Konzipierung und Bauart in der von uns in Verkehr gebrachten Ausführung allen einschlägigen Bestimmungen der nachfolgend aufgeführten EG-Richtlinien entsprechen:

Maschinenrichtlinie	2006/42/EG
EMV-Richtlinie	2014/30/EU
RoHS-Richtlinie	2011/65/EU in Verbindung mit (EU) 2015/863

Die Geräte fallen nicht unter die Druckgeräterichtlinie 2014/68/EU, da die Geräte maximal in die Kategorie 1 eingestuft und durch die Maschinenrichtlinie erfasst sind.

Die Schutzziele der Maschinenrichtlinie in Bezug auf die elektrische Sicherheit werden entsprechend Anhang I Absatz 1.5.1 mit der Konformität zur Niederspannungsrichtlinie 2014/35/EU eingehalten.

Angewandte Normen:

- EN ISO 12100:2010
- EN 61326-1:2013
- EN 61010-1:2010/A1:2019/AC:2019-04
- EN IEC 61010-2-011:2021 /A11:2021
- EN 378-2:2018

Bevollmächtigter für die Zusammenstellung der technischen Unterlagen:

Dr. Jürgen Dirscherl, Leiter Forschung & Entwicklung

Lauda-Königshofen, 04.12.2023



Dr. Alexander Dinger,
Leiter Qualitäts- und Umweltmanagement

QSWA-QA13-055-DE-01

*FAHRENHEIT. *CELSIUS. *LAUDA.

Fig. 146: Declaration of Conformity

13.6 Product Returns and Clearance Declaration

Product Returns

Would you like to return a LAUDA product you have purchased to LAUDA? For the return of goods, e.g. for repair or due to a complaint, you will need the approval of LAUDA in the form of a *Return Material Authorization (RMA)* or *processing number*. You can obtain the RMA number from our customer service department at +49 (0) 9343 503 350 or by email service@lauda.de.

Return address

LAUDA DR. R. WOBSEER GMBH & CO. KG
 Laudaplatz 1
 97922 Lauda-Königshofen
 Deutschland/Germany



Clearly label your shipment with the RMA number. Please also enclose this fully completed declaration.

RMA number	Product serial number
Customer/operator	Contact name
Contact email	Contact telephone
Zip code	Place
Street & house number	
Additional explanations	

Clearance Declaration

The customer/operator hereby confirms that the product returned under the above-mentioned RMA number has been carefully emptied and cleaned, that any connections have been sealed to the farthest possible extent, and that there are no explosive, flammable, environmentally hazardous, biohazardous, toxic, radioactive or other hazardous substances in or on the product.

Place, date	Name in block letters	Signature

  <p style="text-align: right;">Version: V1.0</p>	
<h2>UN38.3 Test Report</h2> <h2>UN38.3 检测报告</h2>	
Applicant's name 委托方名称	LIONTRON GmbH & Co. KG
Applicant's Address 委托方地址	Industriestraße 1, D-41334 Nettetal, Germany
Name of Sample 样品名称	Rechargeable Lithium Iron Phosphate Battery 可充电磷酸铁锂电池
Model 型号	25.6V 100Ah
Testing Laboratory 测试实验室	Shenzhen TCT Testing Technology Co., Ltd. 深圳市通测检测技术有限公司 1B/F., Building 1, Yibaolai Industrial Park, Qiaotou, Fuyong, Baoan District, Shenzhen, Guangdong, China 中国广东省深圳市宝安区福永桥头亿宝来工业城1栋1层B
Report No. 报告编号	TCT191231B118
Date of Issue 签发日期	2020. 07. 09
Test Conclusion 测试结论: The test results are qualified. 测试结果为合格。	
Tested by 主检人: <u>Carry Wang 王琴</u>	Approved by 批准人: <u>Allen Qin 秦超</u>
Inspected by 审核人: <u>Amy Zeng 曾</u>	Seal of TCT 报告单位 (盖章): 
Report No. 报告编号: TCT191231B118 Hotline: 400-6611-140 Tel: 86-755-27673339 E-mail: tom@tct-lab.com http://www.tct-lab.com	

I、Sample Description 样品描述

Name of Sample 样品名称	Rechargeable Lithium Iron Phosphate Battery 可充电磷酸铁锂电池	Model 型号	25.6V 100Ah		
Manufacturer's name 制造商名称	LIONTRON GmbH & Co. KG				
Manufacturer's Address 制造商地址	Industriestraße 1, D-41334 Nettetal, Germany				
Manufacturer's Contact Telephone 制造商联系电话	+49(0)2157 -1449070	E-mail 邮箱	info@liontron. de	Web 网址	https://www.liontron.de
Trade Mark 商标	LIONTRON	Shape 形状	Prismatic 棱形	Size 尺寸 (L×W×T)	(390.0×282.0× 260.0)mm
Nominal Voltage 标称电压	25.6V	Rated Capacity 额定容量	100Ah 2560Wh	Charge Voltage 充电电压	29.2V
Nominal Charge Current 标称充电电流	20A	Maximum Charge Current 最大充电电流	150A	End of Charge Current 结束充电电流	1A
Discharge Cut-off Voltage 放电截止电压	21.6V	Nominal Discharge Current 标称放电电流	20A	Maximum Discharge Current 最大放电电流	160A
Cell Model 电池型号	32650	Cell Nominal Voltage 电池标称电压	3.2V	Cell Rated Capacity 电池额定容量	5300mAh
Cells Number 电池数量	152PCS	Start Testing Date 开始测试日期	2019-07-24	Completing Date 完成日期	2019-08-07

II、Test Standard 检测标准

UNITED NATIONS "Recommendations on the TRANSPORT OF DANGEROUS GOODS Manual of Tests and Criteria" Sixth revised edition Amendment 1 (ST/SG/AC.10/11/Rev.6/Amend.1)
联合国《关于危险货物运输的建议书 试验和标准手册》第六修订版修正 1 (ST/SG/AC.10/11/Rev.6/Amend.1)

TCT 通测检测

TESTING CENTRE TECHNOLOGY

III、Test Item 测试项目

- | | |
|-------------------------------------------------------------------|----------------------------------------------------------------------------------------|
| T.1. <input checked="" type="checkbox"/> Altitude simulation 高度模拟 | T.5. <input checked="" type="checkbox"/> External short circuit 外部短路 |
| T.2. <input checked="" type="checkbox"/> Thermal test 温度试验 | T.6. <input checked="" type="checkbox"/> Impact / <input type="checkbox"/> Crush 撞击/挤压 |
| T.3. <input checked="" type="checkbox"/> Vibration 振动 | T.7. <input checked="" type="checkbox"/> Overcharge 过充电 |
| T.4. <input checked="" type="checkbox"/> Shock 冲击 | T.8. <input checked="" type="checkbox"/> Forced discharge 强制放电 |

IV、Test Method and Requirement 测试方法和要求

T.1. Altitude simulation 高度模拟

Purpose 目的

This test simulates air transport under low-pressure conditions.

本试验模拟在低压条件下的空运。

Test procedure 测试程序

Test cells and batteries shall be stored at a pressure of 11.6 kPa or less for at least six hours at ambient temperature (20 ± 5 °C).

试验电池和电池组应在压力等于或低于 11.6 千帕和环境温度 (20 ± 5 °C) 下存放至少 6 小时。

Requirement 要求

Cells and batteries meet this requirement if there is no leakage, no venting, no disassembly, no rupture and no fire and if the open circuit voltage of each test cell or battery after testing is not less than 90% of its voltage immediately prior to this procedure. The requirement relating to voltage is not applicable to test cells and batteries at fully discharged states.

如果无渗漏、无排气、无解体、无破裂和无起火，并且每个试验电池或电池组在试验后的开路电压不小于其在进行这一试验前电压的 90%，电池和电池组即符合这一要求。有关电压的要求不适用于完全放电状态的试验电池和电池组。

T.2. Thermal test 温度试验

Purpose 目的

This test assesses cell and battery seal integrity and internal electrical connections. The test is conducted using rapid and extreme temperature changes.

本试验评估电池和电池组的密封完善性和内部电连接。试验利用迅速和极端的温度变化进行。

Test procedure 测试程序

Test Cells and batteries are to be stored for at least six hours at a test temperature equal to 72 ± 2 °C, followed by storage for at least six hours at a test temperature equal to -40 ± 2 °C. The maximum time interval between test temperature extremes is 30 minutes. This procedure is to be repeated until 10 total cycles are complete, after which all test cells and batteries are to be stored for 24 hours at ambient temperature (20 ± 5 °C). For large cells and batteries the duration of exposure to the test temperature extremes should be at least 12 hours.

试验电池和电池组应先在试验温度等于 72 ± 2 °C 的条件下存放至少 6 小时，接着再在试验温度等于 -40 ± 2 °C 的条件下存放至少 6 小时。两个极端试验温度之间的最大时间间隔为 30 分钟。此程序重复进行，共完成 10 次，接着将所有试验电池和电池组在环境温度 (20 ± 5 °C) 下存放 24 小时。对于大型电池和电池组，暴露于极端试验温度的时间至少应为 12 小时。

Requirement 要求

Cells and batteries meet this requirement if there is no leakage, no venting, no disassembly, no rupture and no fire and if the open circuit voltage of each test cell or battery after testing is not less than 90% of its voltage immediately prior to this procedure. The requirement relating to voltage is not applicable to test cells and batteries at fully discharged states.

如果无渗漏、无排气、无解体、无破裂和无起火，并且每个试验电池或电池组在试验后的开路电压不小于其在进行这一试验前电压的 90%，电池和电池组即符合这一要求。有关电压的要求不适用于完全放电状态的试验电池和电池组。

T.3. Vibration 振动

Purpose 目的

This test simulates vibration during transport.

本试验模拟运输过程中的振动。

Test procedure 测试程序

Cells and batteries are firmly secured to the platform of the vibration machine without distorting the cells in such a manner as to faithfully transmit the vibration. The vibration shall be a sinusoidal waveform with a logarithmic sweep between 7 Hz and 200 Hz and back to 7 Hz traversed in 15 minutes. This cycle shall be repeated 12 times for a total of 3 hours for each of three mutually perpendicular mounting positions of the cell. One of the directions of vibration must be perpendicular to the terminal face.

The logarithmic frequency sweep shall differ for cells and batteries with a gross mass of not more than 12 kg (cells and small batteries), and for batteries with a gross mass of more than 12 kg (large batteries).

For cells and small batteries: from 7 Hz a peak acceleration of 1 gn is maintained until 18 Hz is reached. The amplitude is then maintained at 0.8 mm (1.6 mm total excursion) and the frequency increased until a peak acceleration of 8 gn occurs (approximately 50 Hz). A peak acceleration of 8 gn is then maintained until the frequency is increased to 200 Hz.

For large batteries: from 7 Hz to a peak acceleration of 1 gn is maintained until 18 Hz is reached. The amplitude is then maintained at 0.8 mm (1.6 mm total excursion) and the frequency increased until a peak acceleration of 2 gn occurs (approximately 25 Hz). A peak acceleration of 2 gn is then maintained until the frequency is increased to 200 Hz.

电池和电池组紧固于振动机平台，但紧固程度不能造成电池变形以致不能准确传递振动。振动应是正弦波形，对数频率扫描从 7 赫兹到 200 赫兹，再回到 7 赫兹，跨度为 15 分钟。这一振动过程须对三个互相垂直的电池安装方位的每一方向重复进行 12 次，总共为时 3 小时。其中一个振动方向必须与端面垂直。

作对数式频率扫描，对总质量不足 12 千克的电池和电池组(电池和小型电池组)，和对 12 千克及更大的电池组(大型电池组)应有所不同。

对电池和小型电池组：从 7 赫兹开始，保持 1 gn 的最大加速度，直到频率达到 18 赫兹。然后将振幅保持在 0.8 毫米(总偏移 1.6 毫米)，并增加频率直到最大加速度达到 8 gn(频率约为 50 赫兹)。将最大加速度保持在 8 gn 直到频率增加到 200 赫兹。

对大型电池组：从 7 赫兹开始，保持 1 gn 的最大加速度，直到频率达到 18 赫兹。然后将振幅保持在 0.8 毫米(总偏移 1.6 毫米)，并增加频率直到最大加速度达到 2 gn(频率约为 25 赫兹)。将最大加速度保持在 2 gn 直到频率增加到 200 赫兹。

Requirement 要求

Cells and batteries meet this requirement if there is no leakage, no venting, no disassembly, no rupture and no fire during the test and after the test and if the open circuit voltage of each test cell or battery directly after testing in its third perpendicular mounting position is not less than 90% of its voltage immediately prior to this procedure. The requirement relating to voltage is not applicable to test cells and batteries at fully discharged states.

如果试验中和试验后无渗漏、无排气、无解体、无破裂和无起火，并且每个试验电池或电池组在第三个垂直安装方位上的试验后立即测得的开路电压不小于在进行这一试验前电压的 90%，电池和电池组即符合本项要求。有关电压的要求不适用于完全放电状态的试验电池和电池组。

T.4. Shock 冲击

Purpose 目的

This test assesses the robustness of cells and batteries against cumulative shocks.

本试验评估电池和电池组对累积冲击效应的耐受程度。

Test procedure 测试程序

Test cells and batteries shall be secured to the testing machine by means of a rigid mount which will support all mounting surfaces of each test battery.

Each cell shall be subjected to a half-sine shock of peak acceleration of 150 gn and pulse duration of 6 milliseconds. Alternatively, large cells may be subjected to a half-sine shock of peak acceleration of 50 gn and pulse duration of 11 milliseconds.

Each battery shall be subjected to a half-sine shock of peak acceleration depending on the mass of the

TCT 通测检测

TESTING CENTRE TECHNOLOGY

battery. The pulse duration shall be 6 milliseconds for small batteries and 11 milliseconds for large batteries. The formulas below are provided to calculate the appropriate minimum peak accelerations.

Each cell or battery shall be subjected to three shocks in the positive direction and to three shocks in the negative direction in each of three mutually perpendicular mounting positions of the cell or battery for a total of 18 shocks.

试验电池和电池组用坚固支架紧固在试验机上，支架支撑着每个试验电池组的所有安装面。

每个电池须经受最大加速度 150 gn 和脉冲持续时间 6 毫秒的半正弦波冲击。不过，大型电池须经受最大加速度 50 gn 和脉冲持续时间 11 毫秒的半正弦波冲击。

每个电池须经受的正弦波冲击的最大加速度取决于电池组的质量。小型电池组的脉冲持续时间 6 毫秒，大型电池组的脉冲持续时间 11 毫秒。以下公式用于计算合适的最低限度最大加速度。

每个电池或电池组须在三个互相垂直的电池或电池组安装方位的正极方向经受三次冲击，接着在负极方向经受三次冲击，总共经受 18 次冲击。

The formulas below are provided to calculate the appropriate minimum peak accelerations. 以下公式用于计算合适的最低限度最大加速度。

Battery 电池组	Minimum peak acceleration 最低限度最大加速度	Pulse duration 脉冲持续时间
Small batteries 小型电池组	150 gn or result of formula Acceleration(g_n) = $\sqrt{\left(\frac{100850}{mass^*}\right)}$ whichever is smaller	6 ms
Large batteries 大型电池组	50 gn or result of formula Acceleration(g_n) = $\sqrt{\left(\frac{30000}{mass^*}\right)}$ whichever is smaller	11 ms

* Mass is expressed in kilograms.

*质量用千克表示

Requirement 要求

Cells and batteries meet this requirement if there is no leakage, no venting, no disassembly, no rupture and no fire and if the open circuit voltage of each test cell or battery after testing is not less than 90% of its voltage immediately prior to this procedure. The requirement relating to voltage is not applicable to test cells and batteries at fully discharged states.

如果无渗漏、无排气、无解体、无破裂和无起火，并且每个试验电池或电池组在试验后的开路电压不小于其在进行这一试验前电压的 90%，电池和电池组即符合这一要求。有关电压的要求不适用于完全放电状态的试验电池和电池组。

T.5. External short circuit 外部短路

Purpose 目的

This test simulates an external short circuit.

本试验模拟外部短路。

Test procedure 测试程序

The cell or battery to be tested shall be heated for a period of time necessary to reach a homogeneous stabilized temperature of 57 ± 4 °C, measured on the external case. This period of time depends on the size and design of the cell or battery and should be assessed and documented. If this assessment is not feasible, the exposure time shall be at least 6 hours for small cells and small batteries, and 12 hours for large cells and large batteries. Then the cell or battery at 57 ± 4 °C shall be subjected to one short circuit condition with a total external resistance of less than 0.1 ohm.

This short circuit condition is continued for at least one hour after the cell or battery external case

temperature has returned to 57 ± 4 °C, or in the case of the large batteries, has decreased by half of the maximum temperature increase observed during the test and remains below that value.

The short circuit and cooling down phases shall be conducted at least at ambient temperature.

对于待试电池或电池组, 应加温一段必要的时间, 使从外壳测量的温度达到均匀的稳定温度 57 ± 4 °C。这段时间的长短取决于电池或电池组的大小和设计, 对于这个持续时间应加以评估和记录。如无法进行这种评估, 则小型电池和小型电池组的暴露时间应至少 6 小时, 大型电池和大型电池组的暴露时间应至少 12 小时。然后, 电池或电池组应在 57 ± 4 °C条件下经受总外电阻小于 0.1 欧姆的短路条件。这一短路条件应在电池或电池组外壳温度回到 57 ± 4 °C后继续至少 1 小时, 或在大型电池组的情况下外壳温度降幅达试验中所观察到的最高温升幅的二分之一并保持低于该数值。

短路和降温阶段的温度应至少相当于环境温度。

Requirement 要求

Cells and batteries meet this requirement if their external temperature does not exceed 170 °C and there is no disassembly, no rupture and no fire during the test and within six hours after the test.

如果外壳温度不超过 170°C, 并且在试验过程中及试验后 6 小时内无解体、无破裂, 无起火, 电池和电池组即符合本项要求。

T.6. Impact / Crush 撞击/挤压

Purpose 目的

These tests simulate mechanical abuse from an impact or crush that may result in an internal short circuit. 本节的试验模拟撞击或挤压等可能造成内部短路的机械性破坏。

Test procedure – Impact (applicable to cylindrical cells not less than 18.0 mm in diameter)

测试程序 – 撞击 (适用于直径不小于 18.0 毫米的圆柱形电池)

The test sample cell or component cell is to be placed on a flat smooth surface. A 15.8 mm \pm 0.1mm diameter, at least 6 cm long, or the longest dimension of the cell, whichever is greater, Type 316 stainless steel bar is to be placed across the centre of the sample. A 9.1 kg \pm 0.1 kg mass is to be dropped from a height of 61 \pm 2.5 cm at the intersection of the bar and sample in a controlled manner using a near frictionless, vertical sliding track or channel with minimal drag on the falling mass. The vertical track or Channel used to guide the falling mass shall be oriented 90 degrees from the horizontal supporting surface.

The test sample is to be impacted with its longitudinal axis parallel to the flat surface and perpendicular to the longitudinal axis of the 15.8 mm \pm 0.1mm diameter curved surface lying across the centre of the test sample. Each sample is to be subjected to only a single impact.

试样电池或元件电池放在平坦光滑的表面上。一根 316 型不锈钢棒横放在试样中心, 钢棒直径 15.8 毫米 \pm 0.1 毫米, 长度至少 6 厘米, 或电池最长端的尺寸, 取二者之长者。将一块 9.1 千克 \pm 0.1 千克的重锤从 61 \pm 2.5 厘米高处跌落到钢棒和试样交叉处, 使用一个几乎没有摩擦的、对落体重锤阻力最小的垂直轨道或管道加以控制。垂直轨道或管道用于引导落锤沿与水平支撑表面呈 90 度落下。

接受撞击的试样, 纵轴应与平坦表面平行并与横放在试样中心的直径 15.8 \pm 0.1 毫米弯曲表面的纵轴垂直。每一试样只经受一次撞击。

Test procedure – Crush (applicable to prismatic, pouch, coin/button cells and cylindrical cells less than 18.0 mm in diameter)

测试程序 – 挤压 (适用于棱柱形、袋状、硬币/纽扣电池和直径小于 18.0 毫米的圆柱形电池)

A cell or component cell is to be crushed between two flat surfaces. The crushing is to be gradual with a speed of approximately 1.5 cm/s at the first point of contact. The crushing is to be continued until the first of the three options below is reached.

- (a) The applied force reaches 13 kN \pm 0.78 kN;
- (b) The voltage of the cell drops by at least 100 mV; or
- (c) The cell is deformed by 50% or more of its original thickness.

Once the maximum pressure has been obtained, the voltage drops by 100 mV or more, or the cell is deformed by at least 50% of its original thickness, the pressure shall be released.

A prismatic or pouch cell shall be crushed by applying the force to the widest side. A button/coin cell shall be crushed by applying the force on its flat surfaces. For cylindrical cells, the crush force shall be applied perpendicular to the longitudinal axis.

Each test cell or component cell is to be subjected to one crush only. The test sample shall be observed

TCT 通测检测

TESTING CENTRE TECHNOLOGY

for a further 6 h. The test shall be conducted using test cells or component cells that have not previously been subjected to other tests.

将电池或元件电池放在两个平面之间挤压，挤压力度逐渐加大，在第一个接触点上的速度大约为 1.5 厘米/秒。挤压持续进行，直到出现以下三种情况之一：

- (a)施加的力量达到 13 千牛顿 \pm 0.78 千牛顿；
- (b)电池的电压下降至少 100 毫伏；或
- (c)电池形变达原始厚度的 50%或以上。

一旦达到最大压力、电压下降 100 毫伏或更多，或电池变形至少达原厚度的 50%，即可解除压力。

棱柱形或袋状电池应从最宽的一面施压。纽扣/硬币形电池应从其平坦表面施压。圆柱形电池应从与纵轴垂直的方向施压。

每个试样电池或元件电池只做一次挤压试验。试样应继续观察 6 小时。试验应使用之前未做过其他试验的电池或元件电池进行。

Requirement 要求

Cells and component cells meet this requirement if their external temperature does not exceed 170 °C and there is no disassembly and no fire during the test and within six hours after this test.

如果外壳温度不超过 170 °C，并且在试验过程中及试验后 6 小时内无解体、无破裂，无起火，电池和电池组即符合本项要求。

T.7. Overcharge 过充电

Purpose 目的

This test evaluates the ability of a rechargeable battery or a single cell rechargeable battery to withstand an overcharge condition.

本试验评估可再充电电池组或可再充电单一电池电池组承受过度充电状况的能力。

Test procedure 测试程序

The charge current shall be twice the manufacturer's recommended maximum continuous charge current. The minimum voltage of the test shall be as follows:

(a) When the manufacturer's recommended charge voltage is not more than 18 V, the minimum voltage of the test shall be the lesser of two times the maximum charge voltage of the battery or 22 V.

(b) When the manufacturer's recommended charge voltage is more than 18 V, the minimum voltage of the test shall be 1.2 times the maximum charge voltage.

Tests are to be conducted at ambient temperature. The duration of the test shall be 24 hours.

充电电流必须是制造商建议的最大持续充电电流的两倍。试验的最小电压如下：

(a)制造商建议的充电电压不大于 18 伏时，试验的最小电压应是电池组最大充电电压的两倍或 22 伏两者中的较小者。

(b)制造商建议的充电电压大于 18 伏时，试验的最小电压应是最大充电电压的 1.2 倍。

试验应在环境温度下进行。进行试验的时间应为 24 小时。

Requirement 要求

Rechargeable batteries meet this requirement if there is no disassembly and no fire during the test and within seven days after the test.

充电电池组在试验过程中和试验后 7 天内无解体、无起火，即符合本项要求。

T.8. Forced discharge 强制放电

Purpose 目的

This test evaluates the ability of a primary or a rechargeable cell to withstand a forced discharge condition.

本试验评估原电池或充电电池承受强制放电状况的能力。

Test procedure 测试程序

Each cell shall be forced discharged at ambient temperature by connecting it in series with a 12 V D.C. power supply at an initial current equal to the maximum discharge current specified by the manufacturer.

The specified discharge current is to be obtained by connecting a resistive load of the appropriate size and rating in series with the test cell. Each cell shall be forced discharged for a time interval (in hours) equal to its rated capacity divided by the initial test current (in ampere).

每个电池应在环境温度下与 12 伏直流电源串联在起始电流等于制造商给定的最大放电电流的条件下强制放电。

将适当大小和额定值的电阻负荷与试验电池串联，计算得出给定的放电电流。对每个电池进行强制放电，放电时间(小时)应等于其额定容量除以初始试验电流(安培)。

Requirement 要求

Primary or rechargeable cells meet this requirement if there is no disassembly and no fire during the test and within seven days after the test.

原电池或充电电池如在试验过程中和试验后 7 天内无解体，无起火，即符合本项要求。

V、General terms and definitions 一般术语与定义

Table 38.3.1: Mass loss limit

表 38.3.1: 质量损失限值

Mass M of cell or battery 电池或电池组质量 M	Mass loss limit 质量损失限值
M < 1 g	0.5%
1 g ≤ M ≤ 75 g	0.2%
M > 75 g	0.1%

In order to quantify the mass loss, the following procedure is provided:

$$\text{Mass loss (\%)} = (M_1 - M_2) / M_1 \times 100$$

质量损失的量化值，可用以下公式计算：

$$\text{质量损失(\%)} = (M_1 - M_2) / M_1 \times 100$$

Where M1 is the mass before the test and M2 is the mass after the test. When mass loss does not exceed the values in Table 38.3.1, it shall be considered as "no mass loss".

式中：M1 是试验前的质量，M2 是试验后的质量。如果质量损失不超过表 38.3.1 所列的数值，应视为“无质量损失”。

Leakage means the visible escape of electrolyte or other material from a cell or battery or the loss of material (except battery casing, handling devices or labels) from a cell or battery such that the loss of mass exceeds the values in Table 38.3.1.

渗漏是指可以看到的电解液或者其他物质从电池或电池组中漏出，或电池或电池组中的物质损失（不包括电池外壳、搬运装置、或标签），质量损失超过表 38.3.1 所列的数值。

Venting means the release of excessive internal pressure from a cell or battery in a manner intended by design to preclude rupture or disassembly.

排气是指按设计方式释放电池或电池组内部过高的压力，防止其破裂或解体。

Disassembly means a vent or rupture where solid matter from any part of a cell or battery penetrates a wire mesh screen (annealed aluminium wire with a diameter of 0.25 mm and grid density of 6 to 7 wires per cm) placed 25 cm away from the cell or battery.

解体是指排气或破裂使电池或电池组任何部分的固体物质穿过放在离电池或电池 25 cm 处的丝网筛（直径 0.25 mm 的软铝丝，网格密度每厘米 6 至 7 条铝丝）。

Rupture means the mechanical failure of a cell container or battery case induced by an internal or external cause, resulting in exposure or spillage but not ejection of solid materials.

破裂是指内部或外部原因引起的电池容器或电池组外壳机械损坏，造成内装物暴露或溢出，但无固体喷射。

Fire means that flames are emitted from the test cell or battery.

起火是指试验电池或电池组有火焰冒出。

TCT 通测检测

TESTING CENTRE TECHNOLOGY

VI、Main Test Apparatus 主要测试仪器

Serial No. 设备编号	Name of Equipment 设备名称	Model 型号	Calibration Date /Due Date 校准日期/到期日
TC-B01	Low Altitude Simulation Tester 低压高空模拟试验箱	GX-3020-Z	2019. 04. 16
			2020. 04. 15
TC-B04	Vertical Shock Test Instrument 垂直冲击试验台	SY10-2	2019. 04. 16
			2020. 04. 15
TC-B05	Vibration test instrument 振动试验台	ES-3-150	2019. 04. 16
			2020. 04. 15
TC-B07	Battery Test System 电池测试系统	CTS 20V/10A	2019. 04. 17
			2020. 04. 16
TC-B11	Crush Test Instrument 温控型电池挤压试验机	BE-6045T	2019. 04. 16
			2020. 04. 15
TC-B13	Battery Short Circuit Tester 电池短路试验机	GX-6055-B	2019. 04. 17
			2020. 04. 16
TC-B14	Electronic Balance 电子天平	PTT-A+300	2019. 04. 16
			2020. 04. 15
TC-B15	Data Collector 数据采集器	34970A	2019. 04. 16
			2020. 04. 15
TC-B18	DC POWER 直流源	PSW 80-27	2019. 04. 16
			2020. 04. 15
TC-B21	Battery Impact Tester 电池冲击试验机	BE-5066	2019. 04. 16
			2020. 04. 15
TC-B25	Digital Multimeter 数字万用表	15B	2018. 09. 11
			2019. 09. 10
TC-B30	Programmable high & low temperature test chamber 可编程式高低温试验机	GX-3000-150	2018. 09. 20
			2019. 09. 19

VII、Test Data 测试数据

T.1. Altitude simulation 高度模拟

Test sample status 测试样品状态	No. 编号	Pre-test 试验前		After test 试验后		Mass loss 质量损失 (%)	Change ratio 电压比(%)	Status 结果
		Mass 质量 (g)	Voltage 电压 (V)	Mass 质量 (g)	Voltage 电压 (V)			
first cycle, fully charged state 首次循环满电状态	1#	27120	27.36	27120	27.36	0.00	100.0	Pass 合格
	2#	27112	27.37	27111	27.35	0.00	99.9	Pass 合格
	3#	/	/	/	/	/	/	/
	4#	/	/	/	/	/	/	/
	5#	/	/	/	/	/	/	/
25th cycle, fully charged state 25次循环满电状态	6#	27119	27.36	27118	27.36	0.00	100.0	Pass 合格
	7#	27119	27.37	27119	27.37	0.00	100.0	Pass 合格
	8#	/	/	/	/	/	/	/
	9#	/	/	/	/	/	/	/
	10#	/	/	/	/	/	/	/

Notes 注释: Ambient temperature 环境温度: 23.5 °C.

After the test, there is no leakage, no venting, no disassembly, no rupture and no fire. And change ratio is not less than 90 %. 测试后, 样品无渗漏、无排气、无解体、无破裂和无起火。电压比不小于 90 %。

T.2. Thermal test 温度试验

Test sample status 测试样品状态	No. 编号	Pre-test 试验前		After test 试验后		Mass loss 质量损失 (%)	Change ratio 电压比(%)	Status 结果
		Mass 质量 (g)	Voltage 电压 (V)	Mass 质量 (g)	Voltage 电压 (V)			
first cycle, fully charged state 首次循环满电状态	1#	27120	27.36	27110	27.21	0.04	99.5	Pass 合格
	2#	27111	27.35	27109	27.25	0.01	99.6	Pass 合格
	3#	/	/	/	/	/	/	/
	4#	/	/	/	/	/	/	/
	5#	/	/	/	/	/	/	/
25th cycle, fully charged state 25次循环满电状态	6#	27118	27.36	27112	27.22	0.02	99.5	Pass 合格
	7#	27119	27.37	27111	27.21	0.03	99.4	Pass 合格
	8#	/	/	/	/	/	/	/
	9#	/	/	/	/	/	/	/
	10#	/	/	/	/	/	/	/

Notes 注释: Ambient temperature 环境温度: 23.4 °C.

After the test, there is no leakage, no venting, no disassembly, no rupture and no fire. And change ratio is not less than 90 %. 测试后, 样品无渗漏、无排气、无解体、无破裂和无起火。电压比不小于 90 %。

TCT 通测检测

TESTING CENTRE TECHNOLOGY

T.3. Vibration 振动

Test sample status 测试样品状态	No. 编号	Pre-test 试验前		After test 试验后		Mass loss 质量损失 (%)	Change ratio 电压比(%)	Status 结果
		Mass 质量 (g)	Voltage 电压 (V)	Mass 质量 (g)	Voltage 电压 (V)			
first cycle, fully charged state 首次循环 满电状态	1#	27110	27.21	27110	27.21	0.00	100.0	Pass 合格
	2#	27109	27.25	27107	27.23	0.01	99.9	Pass 合格
	3#	/	/	/	/	/	/	/
	4#	/	/	/	/	/	/	/
	5#	/	/	/	/	/	/	/
25th cycle, fully charged state 25次循环 满电状态	6#	27112	27.22	27112	27.20	0.00	99.9	Pass 合格
	7#	27111	27.21	27111	27.21	0.00	100.0	Pass 合格
	8#	/	/	/	/	/	/	/
	9#	/	/	/	/	/	/	/
	10#	/	/	/	/	/	/	/

Notes 注释: Ambient temperature 环境温度: 23.5 °C.

After the test, there is no leakage, no venting, no disassembly, no rupture and no fire. And change ratio is not less than 90 %. 测试后, 样品无渗漏、无排气、无解体、无破裂和无起火。电压比不小于 90 %。

T.4. Shock 冲击

Test sample status 测试样品状态	No. 编号	Pre-test 试验前		After test 试验后		Mass loss 质量损失 (%)	Change ratio 电压比(%)	Status 结果
		Mass 质量 (g)	Voltage 电压 (V)	Mass 质量 (g)	Voltage 电压 (V)			
first cycle, fully charged state 首次循环 满电状态	1#	27110	27.21	27108	27.21	0.01	100.0	Pass 合格
	2#	27107	27.23	27106	27.21	0.00	99.9	Pass 合格
	3#	/	/	/	/	/	/	/
	4#	/	/	/	/	/	/	/
	5#	/	/	/	/	/	/	/
25th cycle, fully charged state 25次循环 满电状态	6#	27112	27.20	27112	27.20	0.00	100.0	Pass 合格
	7#	27111	27.21	27110	27.19	0.00	99.9	Pass 合格
	8#	/	/	/	/	/	/	/
	9#	/	/	/	/	/	/	/
	10#	/	/	/	/	/	/	/

Notes 注释: Ambient temperature 环境温度: 23.6 °C.

After the test, there is no leakage, no venting, no disassembly, no rupture and no fire. And change ratio is not less than 90 %. 测试后, 样品无渗漏、无排气、无解体、无破裂和无起火。电压比不小于 90 %。

T.5. External short circuit 外部短路

Test sample status 测试样品状态	No. 编号	Maximum external temperature (°C) 表面最高温度(°C)	Status 结果
first cycle, fully charged state 首次循环满电状态	1#	57.2	Pass 合格
	2#	57.4	Pass 合格
	3#	/	/
	4#	/	/
	5#	/	/
25th cycle, fully charged state 25次循环满电状态	6#	57.4	Pass 合格
	7#	57.6	Pass 合格
	8#	/	/
	9#	/	/
	10#	/	/

Notes 注释: Ambient temperature 环境温度: 23.4 °C。

Test sample external temperature does not exceed 170 °C and there is no disassembly, no rupture and no fire during the test and within six hours after the test.

测试样品表面温度不超过 170 °C, 测试中与测试后 6 小时内无解体、无破裂、无起火。

T.6. Impact 撞击

Test sample status 测试样品状态	No. 编号	Maximum external temperature (°C) 表面最高温度(°C)	Status 结果
first cycle, 50% charged state 首次循环 50%充电状态	11#	32.6	Pass 合格
	12#	32.6	Pass 合格
	13#	36.7	Pass 合格
	14#	35.8	Pass 合格
	15#	34.7	Pass 合格
25th cycle, 50% charged state 25次循环 50%充电状态	16#	33.8	Pass 合格
	17#	35.4	Pass 合格
	18#	32.8	Pass 合格
	19#	33.6	Pass 合格
	20#	35.2	Pass 合格

Notes 注释: Ambient temperature 环境温度: 23.6 °C。

Test sample external temperature does not exceed 170 °C and there is no disassembly, no rupture and no fire during the test and within six hours after the test.

测试样品表面温度不超过 170 °C, 测试中与测试后 6 小时内无解体、无破裂、无起火。

TCT 通测检测

TESTING CENTRE TECHNOLOGY

T.7. Overcharge 过充电

Test sample status 测试样品状态	No. 编号	Status 结果
first cycle, fully charged state 首次循环满电状态	21#	Pass 合格
	22#	Pass 合格
	23#	Pass 合格
	24#	Pass 合格
25th cycle, fully charged state 25 次循环满电状态	25#	Pass 合格
	26#	Pass 合格
	27#	Pass 合格
	28#	Pass 合格

Notes 注释: Ambient temperature 环境温度: 23.5 °C。

There is no disassembly and no fire during the test and within seven days after the test.

样品在测试中和测试后 7 天内无解体、无起火。

T.8. Forced discharge 强制放电

Test sample status 测试样品状态	No. 编号	Status 结果
first cycle, fully discharged state 首次循环完全放电状态	29#	Pass 合格
	30#	Pass 合格
	31#	Pass 合格
	32#	Pass 合格
	33#	Pass 合格
	34#	Pass 合格
	35#	Pass 合格
	36#	Pass 合格
	37#	Pass 合格
	38#	Pass 合格
25th cycle, fully discharged state 25 次循环完全放电状态	39#	Pass 合格
	40#	Pass 合格
	41#	Pass 合格
	42#	Pass 合格
	43#	Pass 合格
	44#	Pass 合格
	45#	Pass 合格
	46#	Pass 合格
	47#	Pass 合格
	48#	Pass 合格

Notes 注释: Ambient temperature 环境温度: 23.5 °C。

There is no disassembly and no fire during the test and within seven days after the test.

样品在测试中和测试后 7 天内无解体、无起火。

VIII、Conclusion 结论

No. 序号	Name of test items 测试项目名称	Cause number of standard 标准条款号	Test Result 检查结果	Conclusion 结论	Remark 备注
1	Altitude simulation 高空模拟	38.3 Test T.1 38.3 试验 T.1	See Appendix T.1. Altitude simulation 见附表 T.1. 高度模拟	Pass 合格	/
2	Thermal test 温度试验	38.3 Test T.2 38.3 试验 T.2	See Appendix T.2. Thermal test 见附表 T.2. 温度试验	Pass 合格	/
3	Vibration 振动	38.3 Test T.3 38.3 试验 T.3	See Appendix T.3. Vibration 见附表 T.3. 振动	Pass 合格	/
4	Shock 冲击	38.3 Test T.4 38.3 试验 T.4	See Appendix T.4. Shock 见附表 T.4. 冲击	Pass 合格	/
5	External short circuit 外部短路	38.3 Test T.5 38.3 试验 T.5	See Appendix T.5. External short circuit 见附表 T.5. 外部短路	Pass 合格	/
6	Impact 撞击	38.3 Test T.6 38.3 试验 T.6	See Appendix T.6. Impact 见附表 T.6. 撞击	Pass 合格	/
7	Overcharge 过度充电	38.3 Test T.7 38.3 试验 T.7	See Appendix T.7. Overcharge 见附表 T.7. 过充电	Pass 合格	/
8	Forced discharge 强制放电	38.3 Test T.8 38.3 试验 T.8	See Appendix T.8. Forced discharge 见附表 T.8. 强制放电	Pass 合格	/

According to the standard:

依据标准:

UNITED NATIONS "Recommendations on the TRANSPORT OF DANGEROUS GOODS Manual of Tests and Criteria" Sixth revised edition Amendment 1 (ST/SG/AC.10/11/Rev.6/Amend.1).

联合国《关于危险货物运输的建议书 试验和标准手册》第六修订版修正 1 (ST/SG/AC.10/11/Rev.6/Amend.1)。

TCT 通测检测
TESTING CENTRE TECHNOLOGY

IX、Picture of the sample 样品图片



Picture 1. Battery view

图片 1. 电池组视图

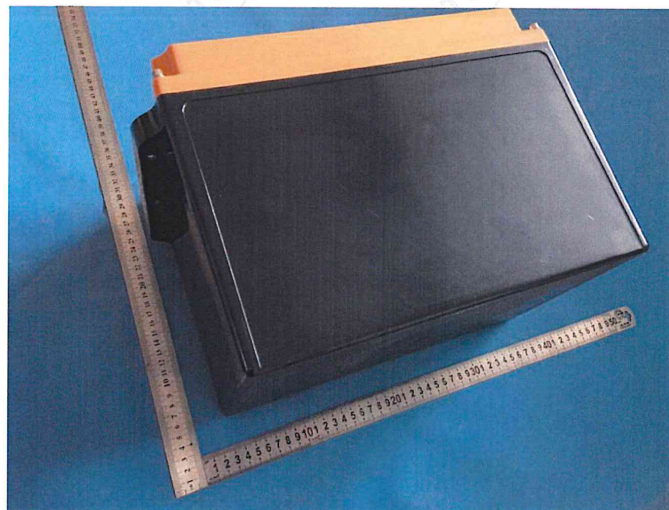

Picture 2. Battery view

图片 2. 电池组视图

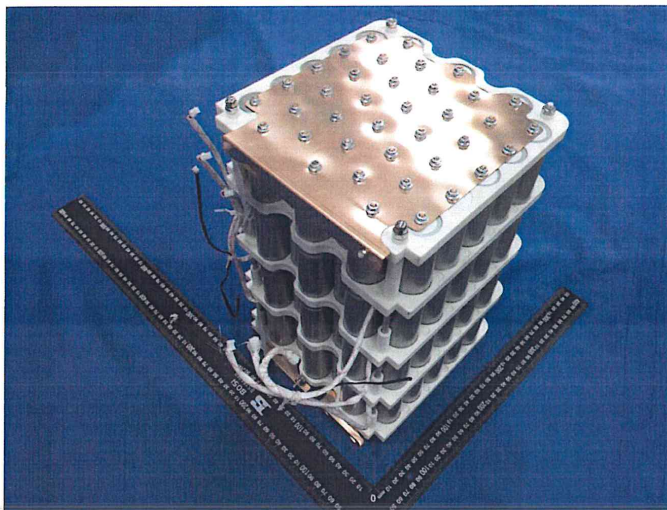

Picture 3. Cell view

图片 3. 电池视图

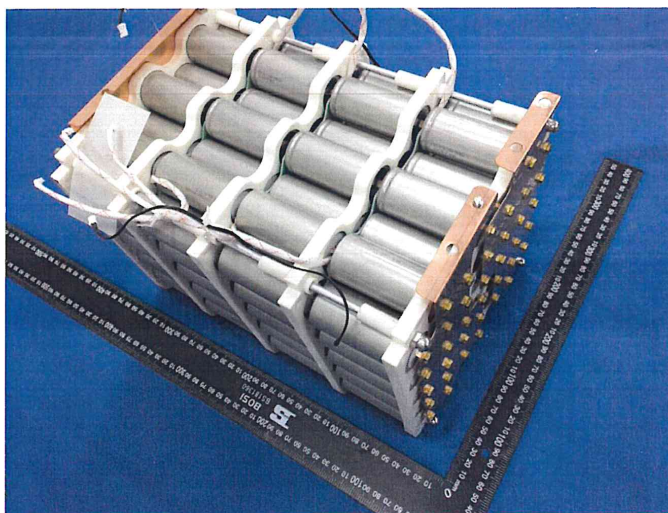

Picture 4. Cell view

图片 4. 电池视图

TCT 通测检测
TESTING CENTRE TECHNOLOGY



Picture 5. Protection board view

图片 5. 保护板视图

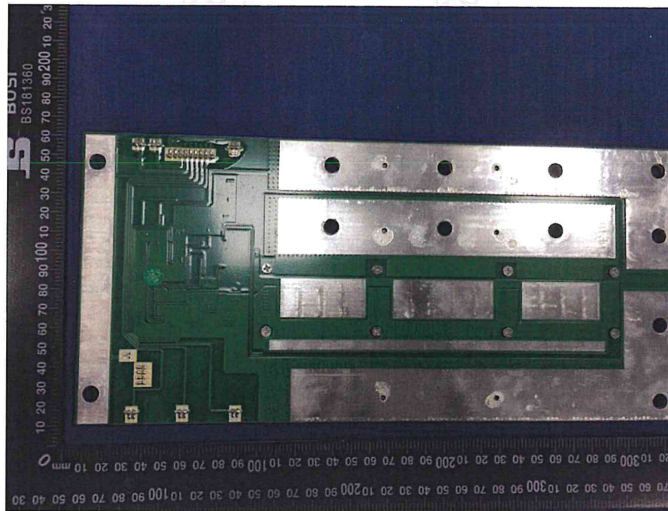

Picture 6. Protection board view

图片 6. 保护板视图

*****End of Report 报告结束*****

Important Notice

注意事项

1. The test report is invalid without the official stamp of TCT.
本报告书无 TCT 盖章无效。
2. Nobody is allowed to photocopy or partly photocopy this test report without written permission of TCT.
未经 TCT 书面同意，不得复制或部分地复制本报告书。
3. The test report is invalid without the signatures of Ratifier, Reviewer and Testing engineer.
本报告书无批准人、审核人、及主检人签名无效。
4. The report is invalid when anything of following happens – illegal transfer, reproduce, embezzlement, imposture, modification or tampering in any media form.
私自转让、复制、盗用、冒用、涂改、或以任何媒体形式篡改的报告书无效。
5. Objections to the test report must be submitted to TCT within 15 days.
对报告书若有异议，应于收到报告之日起 15 天内向本公司提出。
6. The test report is valid for the tested samples only.
本报告仅对本次测试样品有效。
7. The Chinese contents in this report are only for reference.
本报告中的中文内容仅供参考。
8. This report belongs to quote for the record, the reference test report TCT191121B020.
此报告为报备案件，参考测试报告 TCT191121B020。

14 Accessories

Spacer for protective covers

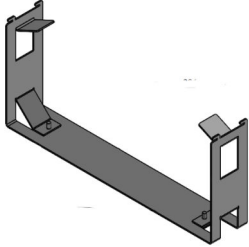

Fig. 147: Spacer

Type	Description	Item number
Spacer for protective covers	<ul style="list-style-type: none"> ■ Made of high-grade stainless steel ■ Required when using protective covers (with the refrigeration unit switched on) 	HLB 569

Device protective cover



Fig. 148: Device protective cover

Type	Description	Item number
Device protective cover	<ul style="list-style-type: none"> ■ Color: light gray ■ Sturdy PVC protective cover ■ With sealable openings for handles ■ Device casters remain fully pivotable ■ Always attach the spacer to the device before using the protective cover (with the refrigeration unit switched on) 	EZ 958

Rain cover



Fig. 149: Rain cover

Type	Description	Item number
Rain cover	<ul style="list-style-type: none"> ■ Transparent and lightweight ■ Provides the device with complete covering ■ Device casters remain fully pivotable ■ Always attach the spacer to the device before using the protective cover (with the refrigeration unit switched on) 	A001747

Side protection set for self-assembly

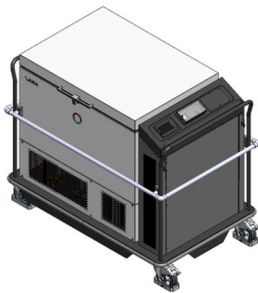

Fig. 150: View of side protection

Type	Description	Item number
Side protection set for self-assembly	<ul style="list-style-type: none"> ■ Tubes made of high-grade stainless steel ■ Corner connectors made of hot-dip galvanized cast steel ■ For self-assembly 	A001871

Anti-slip mat

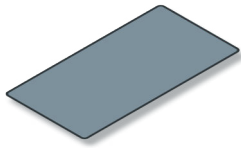

Fig. 151: Anti-slip mat

Type	Description	Item number
Anti-slip mat	<ul style="list-style-type: none"> ■ Color: black ■ For use with L-struts or transport cases ■ Prevents the load from sliding around in the refrigeration compartment ■ Resistance to cold temperatures of up to -110°C, mat thickness = 10 mm 	RDP 033

L-shaped strut

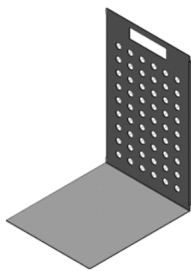

Fig. 152: L-strut

Type	Description	Item number
L-shaped strut	<ul style="list-style-type: none"> ■ Made of stainless steel ■ For attaching larger containers in the refrigeration compartment ■ Use in combination with the anti-slip mat 	A001752

Transport case



Fig. 153: Transport case

Type	Description	Item number
Transport case	<ul style="list-style-type: none"> ■ Made of stainless steel ■ With 2 folding handles and 4 aluminum adjustable feet ■ Insertable metal screen for holding 4, 6 or 9 bottles (bottle size: 0.5 liters and 2 liters) ■ Stackable when using 0.5-liter bottles ■ Device can contain: <ul style="list-style-type: none"> ● 6 crates on one level ● 12 crates on two levels ■ Use in combination with the anti-slip mat 	A001762

Racks



Fig. 154: Racks

Type	Description	Item number
Racks	<ul style="list-style-type: none"> ■ Storage system for cryoboxes with dimensions 136 x 136 mm ■ Stainless steel ■ Device can hold up to 24 racks 	
	Rack for 9 boxes, 52 mm (2 inches)	A001393
	Rack for 6 boxes, 75 mm (2 inches)	A001394
	Rack for 3 boxes, 130 mm	A001395

Cryoboxes



Fig. 155: Cryoboxes

Type	Description	Item number
Cryoboxes	<ul style="list-style-type: none"> ■ Cardboard, white ■ Water-repellent coating ■ Size 136 x 136 mm 	
	Cryobox, 52 mm	A001386
	Cryobox, 75 mm	A001387
	Cryobox, 130 mm	A001388

Grid inserts



Fig. 156: Grid inserts

Type	Description	Item number
Grid inserts	Dividers for inserting into cryoboxes	
	100 compartments, d = 12.5 mm	A001389
	64 compartments, d = 15 mm	A001390
	49 compartments, d = 17 mm	A001391
	16 compartments, d = 31 mm	A001392

15 Index

A		
Ambient conditions	10	
Ambient temperatures	77	
B		
Battery operation	79	
C		
Calculation errors	91	
Cleaning	87	
Condenser fins		
Cleaning the condenser fins	88	
Contact	100	
Copyright	100	
D		
Declaration of Conformity	101	
Defrosting	89	
Device	59	
Cleaning	87	
Decontamination	87	
Disposal (packaging)	96	
Disposal (refrigerant)	96	
Installation	41	
Unpacking	17	
Device version	23	
Disposal		
Packaging	96	
Refrigerant	96	
Disposing of refrigerant	96	
E		
Emissions class	8	
Establishing a mains connection	58	
Establishing a power supply	58	
F		
Faults	91	
Forklift truck forks	23	
I		
Immunity	8	
Industrial truck	22	
Installation (device)	41	
Installation location	41	
L		
LiFePO4 battery	103	
Low temperature alarm	14	
M		
Mains operation	79	
Mains switch		
Operation	34	
O		
Operating conditions	10	
Option	23	
Overtemperature alarm	14	
P		
Packaging		
Disposal	96	
Personal protective equipment (overview)	13	
Personnel qualifications (overview)	12	
Protective equipment (personal, overview)	13	
R		
Refrigerant		
Flammable	11	
Refrigeration compartment	89	
S		
Safety information		
General	7	
Service	100	
Switching off	59	
Switching on	59	
T		
Test report	103	
Transport	22	

Type plate	37
U	
Unpacking	17
W	
Warranty	100

Manufacturer:

LAUDA DR. R. WOBSE GMBH & CO. KG ° Schulze-Delitzsch-Straße 4+5 ° 30938 Burgwedel

Telephone: +49 (0)9343 503-350

E-mail: info@lauda.de ° Internet: <https://www.lauda.de>